

# FUJIIRYŌKI

## Instruction Manual

Thank you very much for purchasing our product.  
This “Instruction Manual” describes important items  
for use. Fully read and understand this Manual  
before use in order to use the product correctly.

# HWP-55(EN)

**Alkaline ionized water apparatus**

For household use only

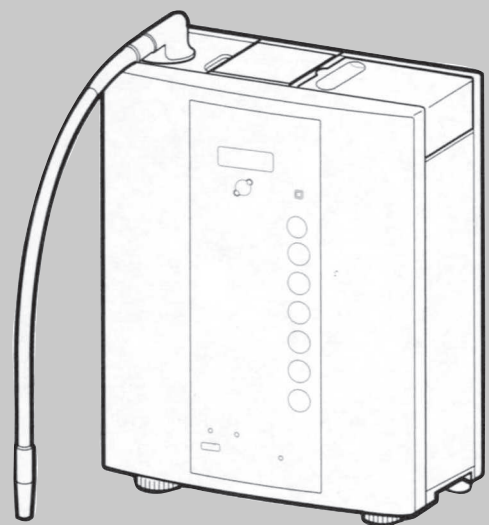



空 白











Contents	
Safety precautions (Make sure to observe) .....	4
Before use .....	8
Name of each part .....	9
How to mount corporation stop .....	13
Installation of main body .....	16
Installation of delivery pipe .....	19
Installation of drain hose .....	19
Connection of water supply hose .....	20
Using alkaline ionized water, acid water and purified water .....	21
When pH value of alkaline ionized water is low	24
Observing hydrogen level .....	25
Observing ORP value .....	25
Observing flow rate .....	25
Observing filter life .....	26
Generation of sanitized water .....	27
Procautions for use .....	29
Measuring pH value .....	30
Cleaning inside of the main body .....	31
Maintenance .....	32
Anti-freezing .....	32
Filter replacement .....	33
Addition of electrolysis auxiliary .....	37
When failure is suspected .....	38
Specifications .....	41

# Safety precautions (Make sure to observe)

- The precautions described here are intended for you to use the product safely and correctly, and prevent hazards or injury to you and other persons before they occur.
- The precautions are classified as follows.  
All of the items are related to safety and important matters, therefore, make sure to observe them.













 <b>WARNING</b>	Extent of hazard that improper operation is predicted to result in death or serious injury to users.
 <b>CAUTION</b>	Extent of hazard or damage that improper operation is predicted to result in injury to users or physical damage.

## <Example of pictorial indication>

	<p> symbol indicates “Prohibited” (do not perform).</p> <p> “Disassembly prohibited”    “Use in a place with water prohibited”</p> <p> “Keep dry”    “Wet hands prohibited”    “Keep fire away”</p>
	<p> symbol indicates “Mandatory” (make sure to perform).</p> <p> “General action”</p> <p> “Remove the power plug from the power outlet”</p>

- After reading, make sure to keep this Manual in an easy to access location where users can refer to it at any time.

**⚠ WARNING**

 Prohibited	Do not use water other than water acceptable for drinking (tap water). (Poor physical condition may result.)
	Do not use this product by any method exceeding the rating of power outlet or wiring appliance and at power supply other than an alternating current of 220V. (Fire or electric shock may result.)
	Do not damage power cord or power plug. - Do not fix with a staple  - Do not compromise - Do not rework - Do not forcibly bend  - Do not twist  - Do not pull - Do not bring close to thermal appliance  - Do not put heavy object on top of - Do not bundle  - Do not sandwich (Use with damage may result in electric shock, short-circuit or fire.) <ul style="list-style-type: none"> <li>• When removing power plug, hold the power plug without holding the cord.</li> <li>• Consult with the store where you purchased this product to repair power cord or power plug.</li> </ul>
	When power cord or power plug are damaged, or the plug is loosely inserted into power outlet, do not use. (Electric shock, short-circuit or ignition may result.)
 Make sure to observe	If you accidentally drop the main body in water, remove the power plug from the power outlet, and remove the main body from the water. (Electric shock may result.) <ul style="list-style-type: none"> <li>• Make sure to consult with the store where you purchased this product for repair.</li> </ul>
	Remove dust adhered to the power plug. (Accumulation of dust on the power plug may cause insulation failure due to moisture, resulting in fire.) <ul style="list-style-type: none"> <li>• Remove the power plug from the power outlet, and wipe off dust with a dry cloth.</li> </ul>
	Completely insert the power plug into a power outlet. (Insufficient insertion may result in electric shock and fire due to heat generation.)
 Remove the power plug	When performing maintenance, make sure to remove the power plug from power outlet. (Electric shock may result.)
 Keep dry	Do not wash main body with water and do not splash water. (Electric leakage or electric shock may result.)
 Use in a place with water prohibited	Do not use this product in a humid place such as a bathroom. (Electric leakage or electric shock may result.)
 Wet hands prohibited	Do not insert or remove power plug with wet hands. (Electric shock may result.)
 Disassembly prohibited	Never remodel, disassemble or repair this product. (Fire or electric shock may result.) <ul style="list-style-type: none"> <li>• Consult with the store where you purchased this product for repair.</li> </ul>

# Safety precautions (Make sure to observe)

## ⚠ CAUTION



Make sure to observe

Persons described below should consult with a doctor before drinking alkaline ionized water.

- A person who has any chronic disease, is weak in body or feels any abnormality in body.
- A person who is receiving medical treatment from a doctor, in particular, has a problem with kidneys.

When you feel any abnormality from drinking alkaline ionized water, stop using and consult with a doctor.

A person who drinks for the first time should set to alkaline 1 (rough standard 8.5 of pH value), drink little-by-little (one or two cups), and increase pH value and amount according to physical condition after getting used to alkaline ionized water.

- If drinking or using strong alkaline ionized water of high pH initially, you may suffer from a poor physical condition.

Persons described below should consult with a doctor before using acid water.

- A person with sensitive skin. - Allergic person.

When feeling any abnormality with your skin by using acid water, stop using and consult with a doctor.

Use alkaline ionized water, purified water and acid water immediately after generating. When reserving, put water into a clean enclosed container and use it within two days after storing in a refrigerator.

- Because disinfection agent (such as chlorine) is removed in alkaline ionized water and purified water, bacteria tends to increase, therefore, you may suffer from a poor physical condition when drinking and using water which has been stored for a long time.

Discharge accumulated water in the main body at the beginning of use.

- Pass water of about 1 liter or more at the beginning of daily use.
- If not used for two days or longer, pass water for two minutes or longer before use even when the digital display part changes from flashing to lit.

A person with a kidney disease (kidney failure and potassium excretion disorder) should not drink alkaline ionized water.

Do not take medicinal drugs with alkaline ionized water.

Do not directly drink water of pH10 or more (strong alkaline ionized water). (Poor physical condition may result.)

- It is recommended to drink water of about pH9.5 (alkaline ionized water 3) (daily use). Amount of drinking for one day should be 0.5 liters to 1 liter as a rough standard.



Prohibited

Do not drink water described below. (Poor physical condition may result.)

- Acid water - Water coming out from drainage hose - Water during cleaning
- Sanitized water

Do not put in anything other than calcium glycerophosphate.

(Poor physical condition may result.)

- Use the option.



Do not use anything other than the included pH test liquid.

- Use the accessories or separately sold product.

Do not use aluminum container sensitive to alkaline and copper container sensitive to acid.

- Discoloration or damage to container may result.

## ⚠ CAUTION

 Prohibited	<ul style="list-style-type: none"> <li>● Do not flow hot water of 35°C or higher to the main body. (Failure may result.)</li> <li>● Do not flow hot water of 60°C or higher to the corporation stop. (Burn injury or failure may result.)</li> </ul>
	Do not use alkaline ionized water, acid water or purified water as breeding water for fish. Change in environment may cause fish to die.
	Do not drink water containing pH test liquid or test liquid, or do not put into eyes. (Poor physical condition may result.)
	Do not drink water while the Cleaning lamp, Rinsing lamp or digital display is flashing. (Poor physical condition may result.)
	Never drink sanitized water because it is a strong acid water of about pH2.5. (Poor physical condition may result.)
	When feeling any abnormality with your body by using sanitized water, immediately stop use and consult with a doctor.
	Do not store sanitized water. (Generated chlorine may result in poor physical condition.)
	Do not soak metallic dishes or rings in sanitized water. (Rust and discoloration may result.)
 Keep fire away	As the pH test liquid contains alcohol, do not bring it close to fire. (Fire may result)
	<p>After installation and if not used for a long time (one week or longer as a rough standard), make sure to measure pH value with the included pH test liquid, and confirm that alkaline ionized water 3 (pH value of 9.5 as a rough standard) does not exceed pH10 before use. Periodically measure it after that (more frequently than once a month).</p>
 Make sure to observe	When removing the power plug from the power outlet, make sure to hold the power plug without holding the power cord. (Electric shock, short-circuit or ignition may result.)
	When not in use for a long time (one week or longer as a rough standard), make sure to remove the power plug from the power outlet.
	When using the main body with a wall mount, make sure to consult with the store where you purchased this product for installation. (Accidents such as falling off of the main body may result.)
	When generating, using or draining sanitized water, use in a well-ventilated place by turning on a ventilation fan or opening a window because a chlorine odor occurs. (Poor physical condition may result.)
	If sanitized water or water coming from the drain hose gets into your eyes, immediately rinse eyes out with tap water. (Poor physical condition may result.)
	After generating, using or draining sanitized water in a stainless steel sink, rinse out sink with tap water. (Discoloration of sink may result.)
	When sanitized water splashes on clothing or hair, rinse clothing or hair off with tap water. (Discoloration may result.)

● **Proper use of 4 kinds of water** For optimal use according to application

pH adjustment button		Application	Rough Standard of pH value
Alkaline hydrogen	Strong (4)	For cooking ingredients with a lot of scum (burdock root, konjac). (⚠ CAUTION) Do not drink directly.	10~11
	3	For daily drinking, such as coffee, tea, cooked food, soup.	9~9.9
	2	For getting used to drinking, for cooking rice.	8.5~9.5
	1	When beginning to drink.	8~9
Purified water		Water filtered by filter. For taking medicinal drugs, milk and drinking. ※Electrolysis is not applied.	—
Acid water		For washing your face. (⚠ CAUTION) Do not drink.	4.5~6.5
Sanitized water		For passing water and cleaning cutting board. (⚠ CAUTION) Do not drink.	2.5~3.5

● **Built-in “No discharge water mode”**

There is no discharge water when generation starts while the “No discharge water” lamp is lit, and you can use it immediately.

● **Easily visible digital display**

- The water in use can be checked at a glance by the digital display.
- The digital display shows pH, hydrogen level, ORP (Oxidation Reduction Potential), total flow rate, and passing water amount (remaining usable filter amount).

● **Built-in “Hydrogen plus mode” and “Hi mode” which increase electrolytic capacity at the press of a button**

This is easily set in a region where pH value is difficult to increase.

Use the “Hydrogen plus mode” when the pH value is lower than the rough standard for pH values. Use the “Hi mode” if the pH value does not reach the rough standard range even when using the “Hydrogen plus mode.”

※The amount the pH value increases depends on water quality and operating conditions.

● **What is pH of water?**

pH represents the amount of hydrogen ions in water and is an index representing whether water is alkaline or acidic.

Acid (Smaller numerical value) ← Neutral (7) → Alkaline (Larger numerical value)

● **What is hydrogen level?**

Hydrogen level represents a rough standard of the hydrogen amount on the alkali side that is generated by electrolysis of water.

● **What is water ORP?**

Water ORP is an index representing the electric energy to oxidize or reduce object.

- The higher the positive value, the stronger the power to oxidize is.
- The lower the negative value, the stronger the power to reduce is.



# Name of each part

continued

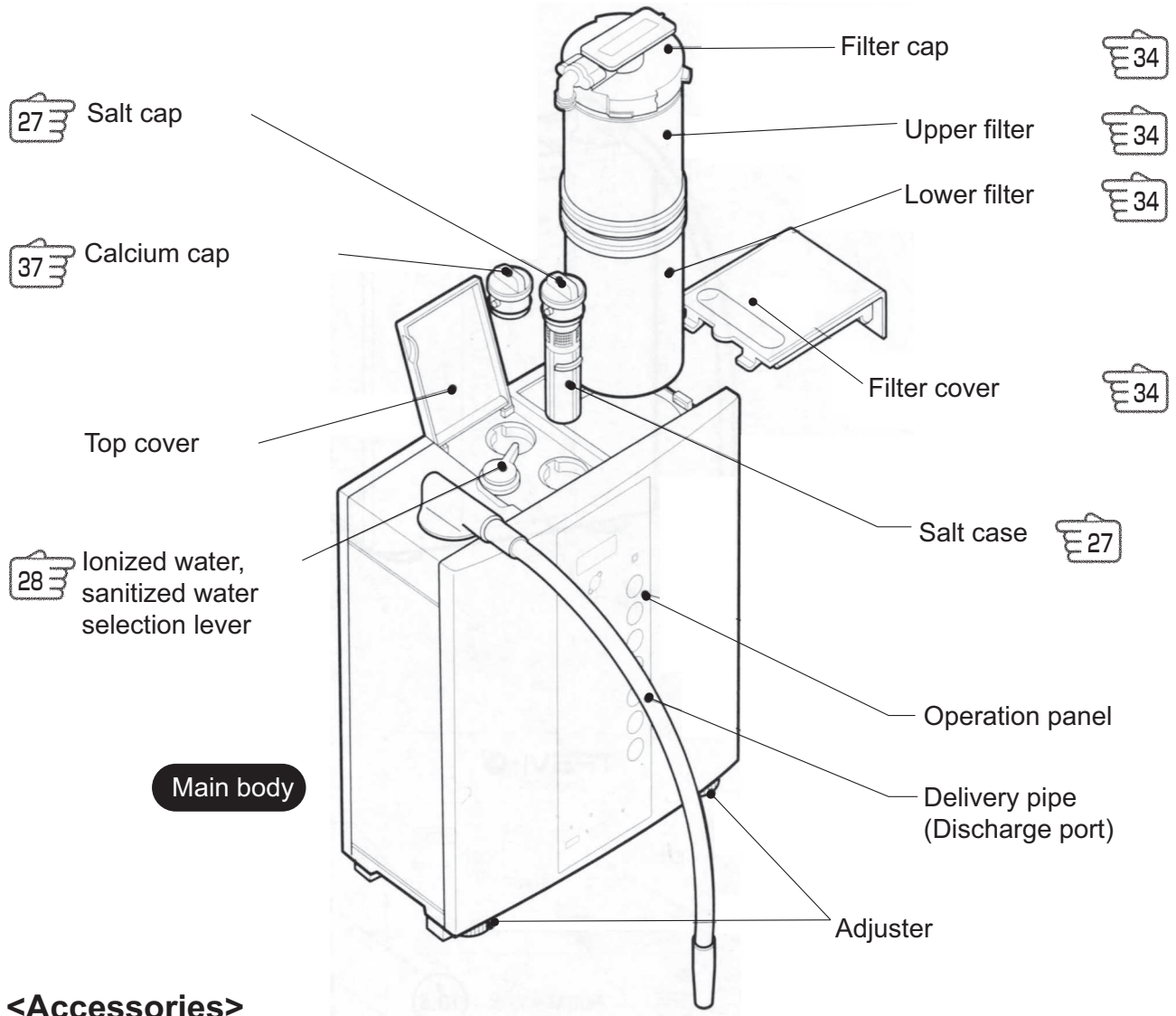

## <Accessories>

<p>Corporation stop</p>	<p>Wood screw for wall mounting 2 pieces</p>	<p>★カートリッジ使用開始日 年 月 日 この装置が初めて使用された日に1000時間 を経過します。 (100000001時) ★カートリッジのご購入先案内 ●お近くの販売店でお取り寄せください ●お電話でお問い合わせください ●お近くの販売店 ●お電話でお問い合わせ ●お電話: 02-26-26-2626 ●お電話: 02-26-26-2626</p>	<p>Filter replacement seal 2 sheets</p>
<p>Delivery pipe</p>	<p>Accessory for mounting corporation stop</p>	<p>Salt (Sanitized water generation auxiliary) 5g in 1 pack (3 packs included)</p>	
<p>Suction cup (for fixing drain hose)</p>	<p>Hose fixing band (2 pieces)</p>	<p>pH test liquid set pH test liquid pH test color paper Dedicated cup</p>	

# Name of each part

## <Operation panel>

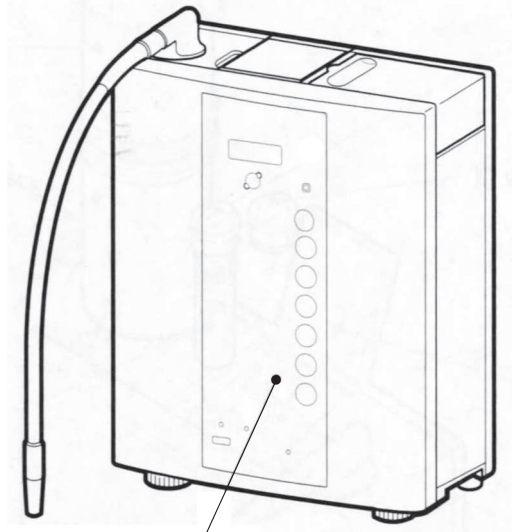

Operation panel

Number in indicates the page where explanation is given.

### Digital display

The pH value, hydrogen level and ORP value of water coming out from the delivery pipe, the combined total flow rate of water coming out from the delivery pipe and drainage hose, and the usable passing water amount of the filter are displayed. (The above numerical values are rough standards)

※ The pH value, hydrogen amount and ORP value of the actual generated water may not be stable, and an error may occur in the passing water amount due to variations in water quality and flow rate.

24 Hydrogen plus button

31 Cleaning lamp

36 Filter life setting button / lamp

33 Change filter lamp

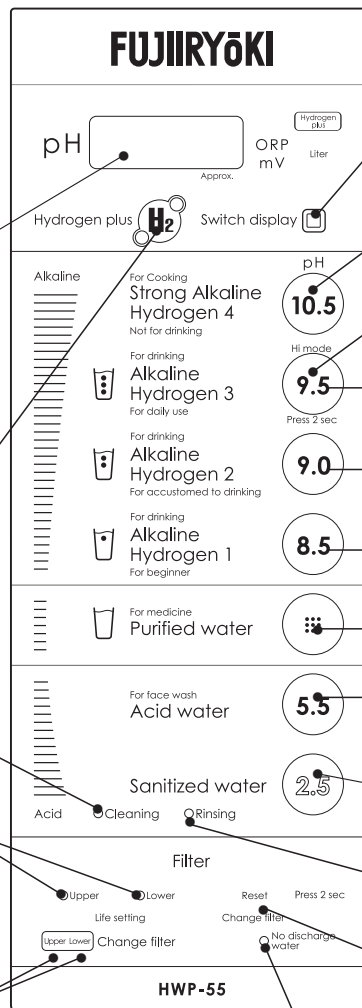

Switch display button 22

Strong alkaline hydrogen button 22

“Hi mode” setting button (Set by holding for 2 seconds) 24

Alkaline hydrogen button 22

Purified button 22

Acid button 22

Sanitized water lamp 28

Rinsing lamp 28

Change filter reset button 35

No discharge water lamp 22

<Ionized water, sanitized water selection lever indicator>

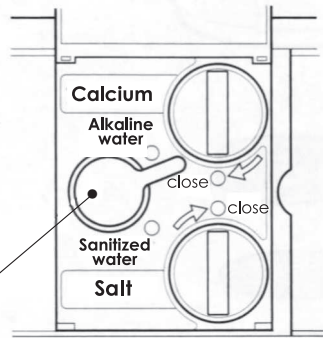

Ionized water, sanitized water selection lever  
 ※ Securely set the lever to a position where it stops.

<Installation completion drawing>

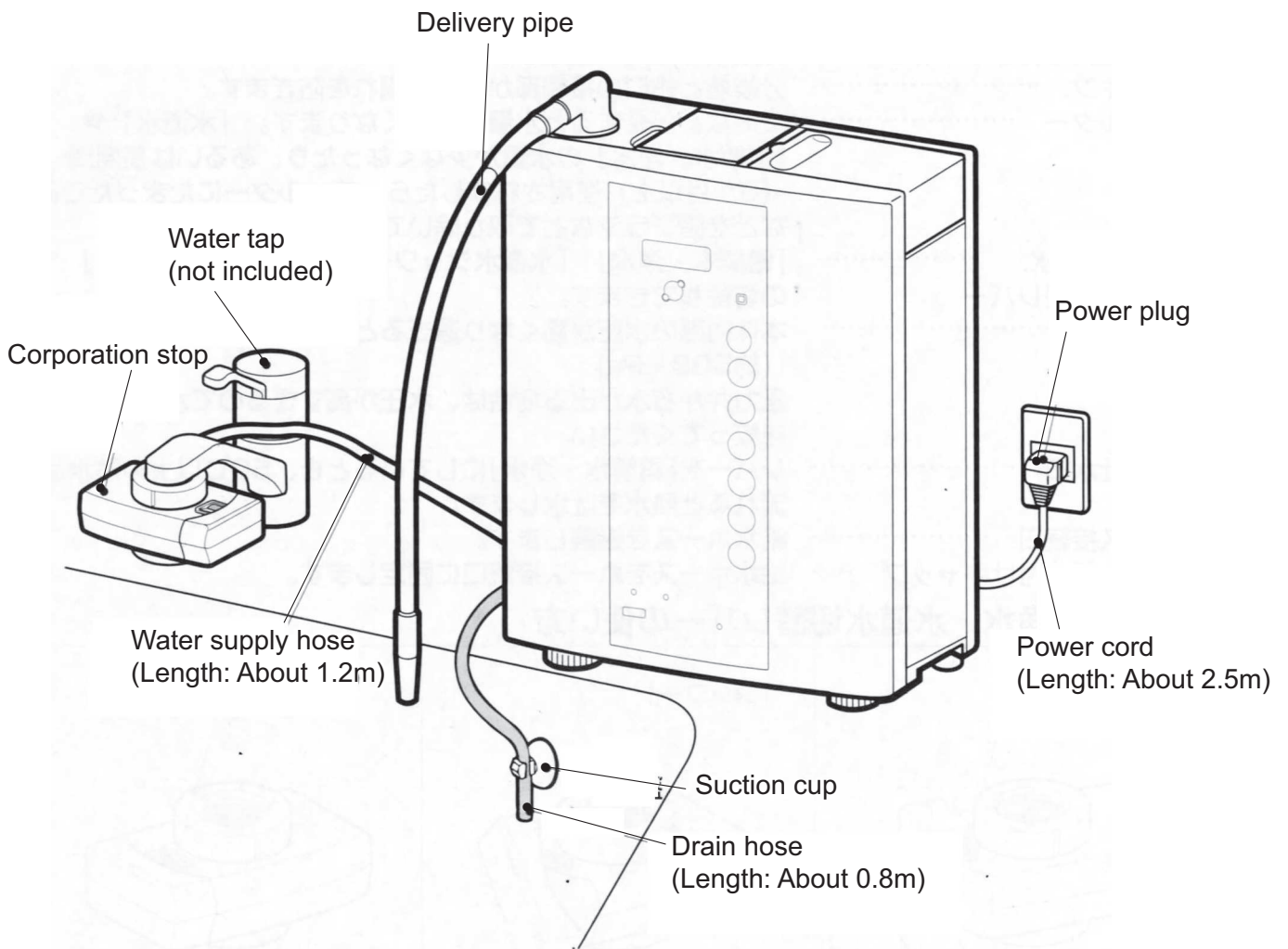

※ Install in a stable position around sink.

# Name of each part

## <Corporation stop>

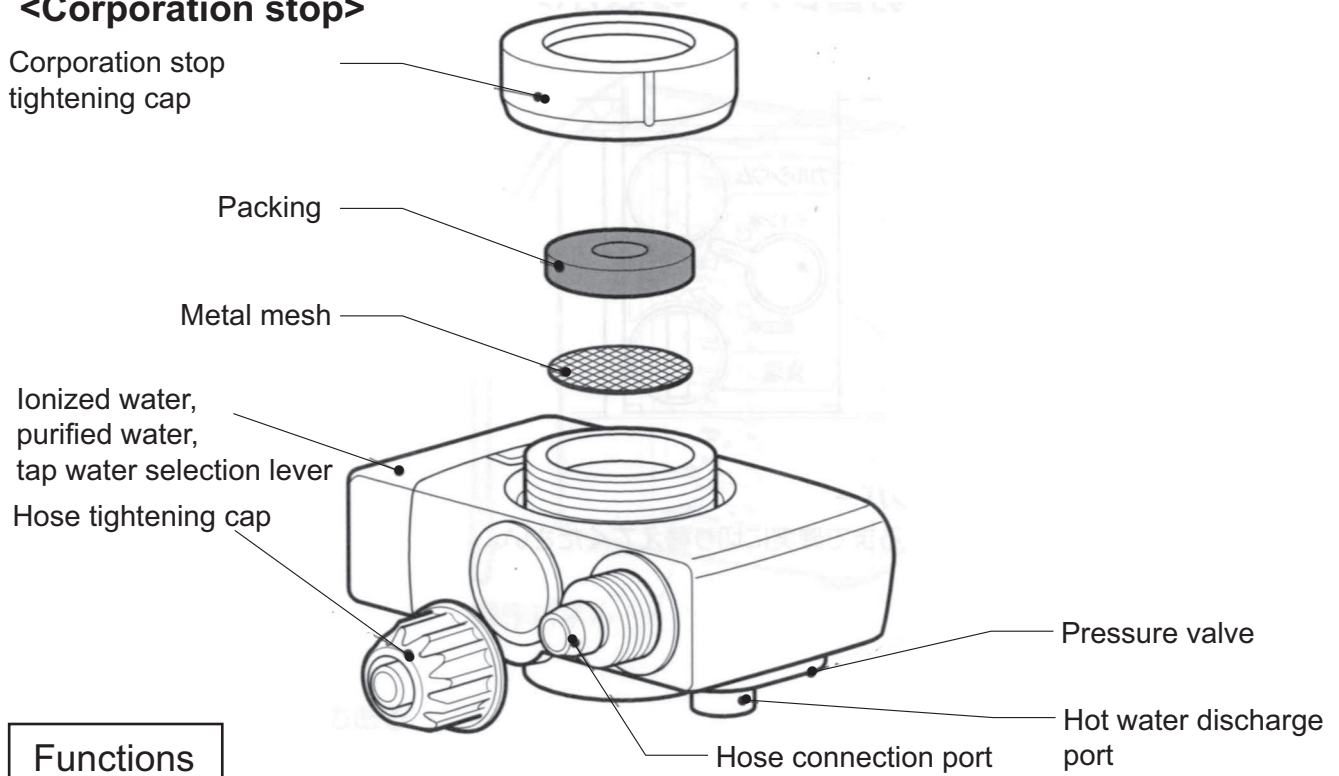

### Functions

- Corporation stop tightening cap .. Fixes corporation stop to water tap.
- Packing ..... Prevents water leak from the connection parts of the corporation stop and water tap.
- Metal mesh ..... When the metal mesh has clogged with contaminants, water quantity decreases. If water quantity of “tap water” and “ionized water and purified water” decreases, or after use for a long time (6 months or longer), remove contaminants which have accumulated in the metal mesh with a toothbrush or a similar object.
- Ionized water, purified water, tap water selection lever ..... Allows to select from “Ionized water and purified water,” “tap water shower” or “tap water straight.”
- Pressure valve ..... This valve opens to discharge water when water pressure in the main body is excessively high. (About 500kPa)  
When water comes out of the pressure valve, choke the cock of the water tap because water pressure is excessively high.
- Hot water discharge port ..... When the lever is set to “Ionized water and purified water,” hot water is discharged if hot water of 50°C or higher flows.
- Hose connection port ..... Connect a water supply hose.
- Hose tightening cap ..... Fixes the water supply hose to the hose connection port.
- How to use the Ionized water, purified water, tap water selection lever



## ⚠ CAUTION





Make sure to observe

Use ionized water and purified water at water temperature of lower than 35°C (Failure may result.)

Select accessories for mounting suitable to screw diameter of water tap. (Water leakage may result.)

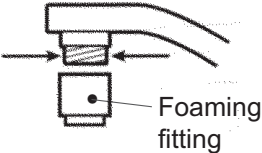
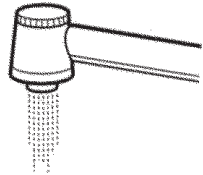
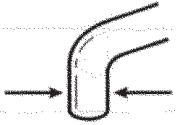
Corporation stop cannot be mounted to the following water taps.

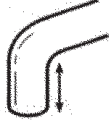
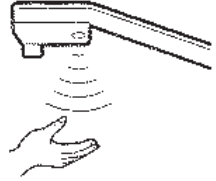
<p>Different screw diameter Not 22mm</p>		<p>With shower</p>	
<p>Water tap diameter 25mm or more</p>		<p>Deformation Special screw diameter</p>	
<p>Tip end is 15mm or less</p>		<p>With sensor</p>	

# How to mount corporation stop

## Information

Water may leak from installation parts of plastic water tap. It is recommended to replace the water tap.

## Installation of this part.

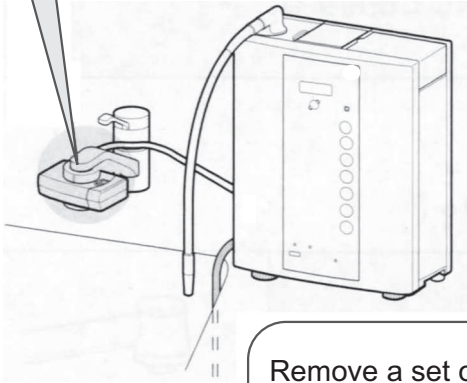

When there is a foaming fitting at the tip end of the water tap

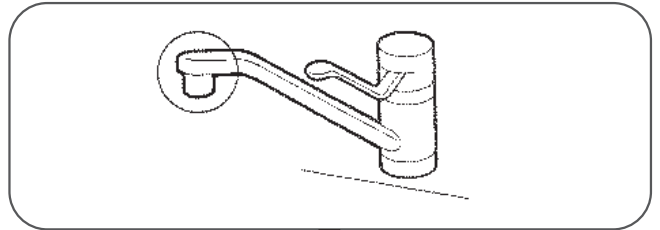

Remove a set of the foaming fittings.



Turn the accessory for outside screw or inside screw with a coin or a similar object, and install the corporation stop tightening cap to the water tap.

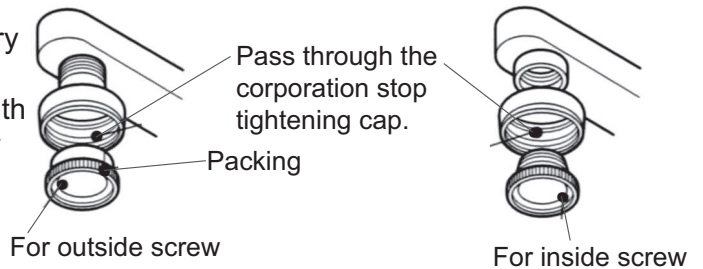

Apply the corporation stop horizontally from below and tighten the corporation stop tightening cap.

Corporation stop tightening cap

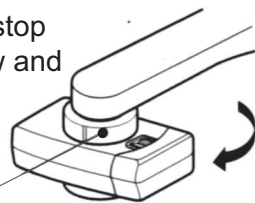

## CAUTION

Do not use any tools to mount the corporation stop tightening cap. (Breakage may result.)

If there is any bulge at the tip end of the water tap

Use the backing of the corporation stop mounting accessory to measure the diameter of the pipe and select a fixing ring to be used.

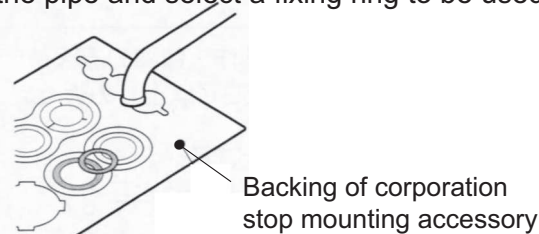

Pass the corporation stop tightening cap through the pipe.

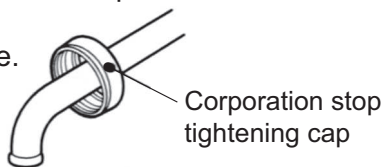

Insert the fixing ring to the end of the pipe.

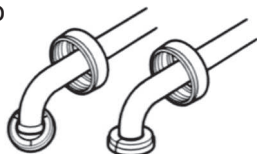

Direct the cutout of the fixing ring toward you so as to easily insert.

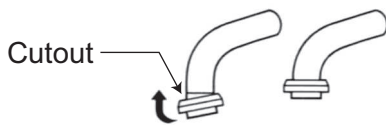

Apply the corporation stop to the water tap horizontally and tighten the corporation stop tightening cap.

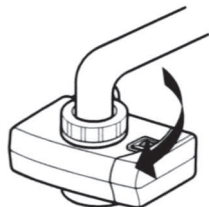

**CAUTION**

Do not use any tools to mount the corporation stop tightening cap. (Breakage may result.)

If the end of the water tap is straight and not stepped

**How to install a screw clamp**

※ No screw clamp is packed together with this product. Place an order with the store where you purchased this product.

(If the corporation stop mounting accessories of 16mm, 17.5mm and 19mm cannot be used)

Remove the screw and pass the fitting through the corporation stop tightening cap.

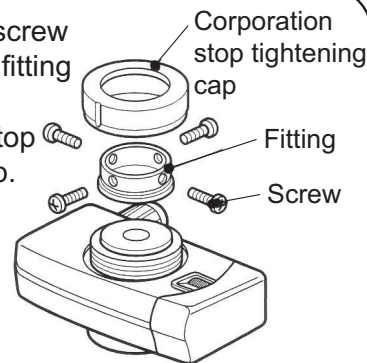

Mount the screw again.

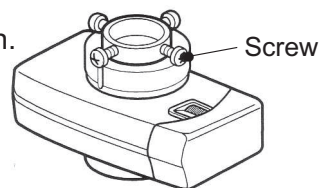



Loosen the screw and set the corporation stop horizontally, and tighten the screw while pressing it against the water tap. Do not excessively tighten the screw. (The water tap may be perforated.)

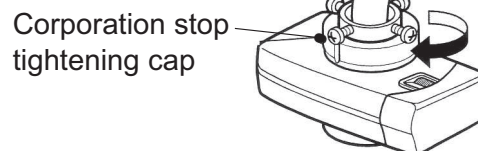

Tighten the corporation stop tightening cap.



# Installation of main body

⚠ CAUTION	
 Make sure to observe	Install so that the main body is horizontal. Do not install in an unstable place such as on a wobbling stand or inclined surface. (The main body may drop or fall off, resulting in injury.)
 Prohibited	Do not install in places described below. (Deformation, discoloration, malfunction or failure may result.) - Place where fire is used, or near object that gets hot (60°C or higher) - On and near microwave oven, electromagnetic range, refrigerator - Place subject to direct sunlight - Place where oil adheres - Outdoors or place subject to wind and rain - Bathroom and place subject to water or steam - Place which may freeze
	Do not extend water outlet with commercially available hose. (Failure may be result.)
	Do not connect other equipment to water supply and drain hoses. (Water leakage or failure may be result.)
	Do not block water outlet and do not bend, twist or crush hose. (Appropriate pH value cannot be obtained, or water leakage or failure may result.)
	Do not install on hot-water supply facility without check valve (backwater valve). (Failure of hot-water supply facility may result.)
	Do not install to water tap dedicated to hot water. (Failure may result.)
	Prevent the main body from pressing the power cord, water supply hose, and drain hose. (Water leakage or failure may result.)

## When installing in an inclined place

Adjust the length of the front leg according to the inclination with the adjuster.

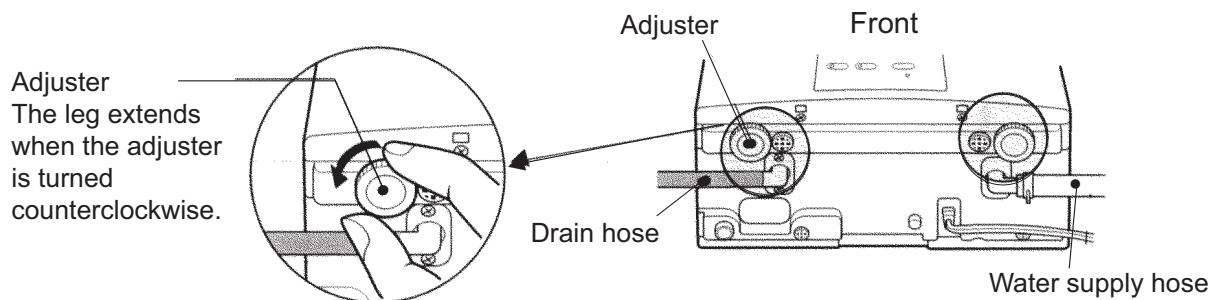

- Install so that the main body is horizontal.

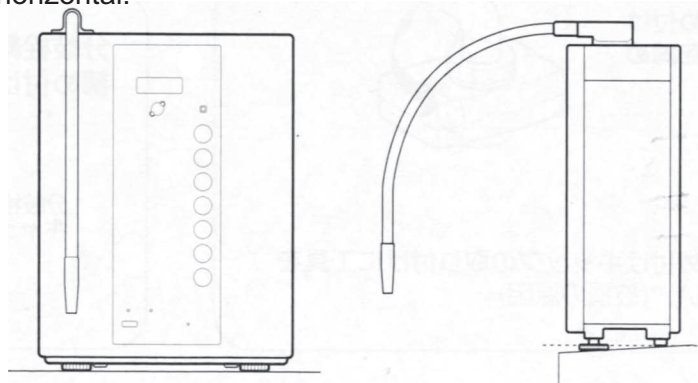



## When mounting on a wall for use

### ⚠ CAUTION



Make sure to observe

When mounting the main body on a wall for use, make sure to request the store where you purchased this product for installation.  
(Installation on your own may result in falling off, leading to an accident.)

1

Cut out the “Screw hole position diagram for wall mounting” on page 18 from the cutoff line, affix it with tape or a similar object, and screw in the attached wood screws over the position diagram. (Leave 8 to 9mm.)

※ Screw the wood screws in the holes for either vertical or horizontal installation.

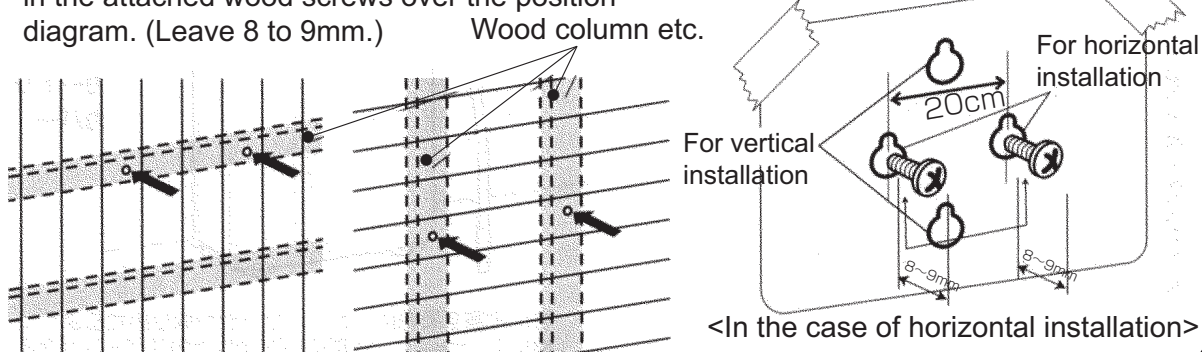

2

Hang the main body using the mounting holes on the back.

Make sure to use the attached wood screws.

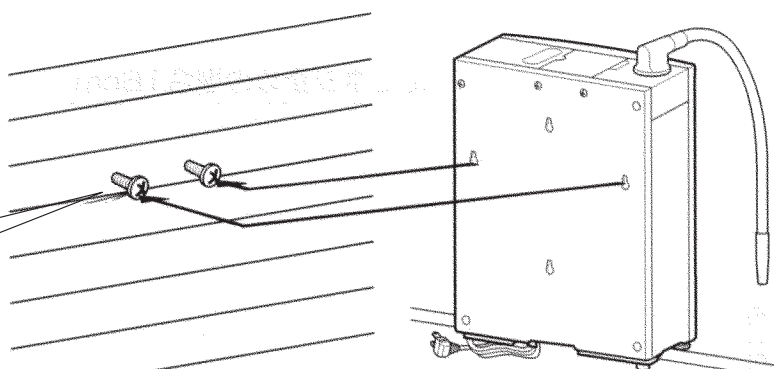

<In the case of horizontal installation>

### <CAUTION>

- Do not install on plywood and soft wall surfaces because the weight of the main body when full of water is approx. 6.5kg.
- When installing on a wall, install in a place where there is a space of 11cm or more on the right side of the main body and 30cm or more above the main body so that the filter can be removed.
- Install at a height where the ionized water and sanitized water selection lever is visible.

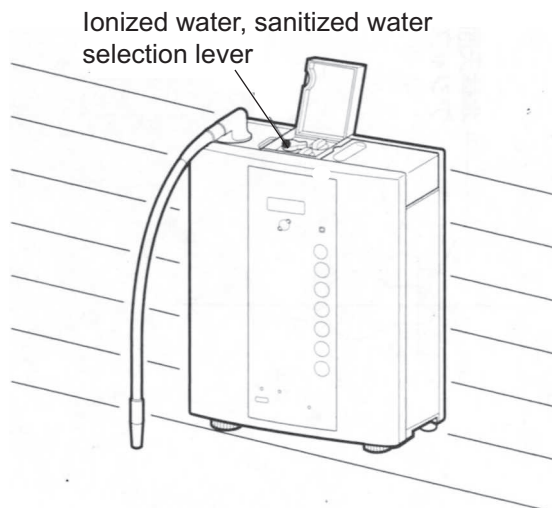

## [Screw hole position diagram for wall mounting]

Cut the sheet from the cutoff line with scissors to use it for positioning the screw holes. Make sure to keep the sheet after use.

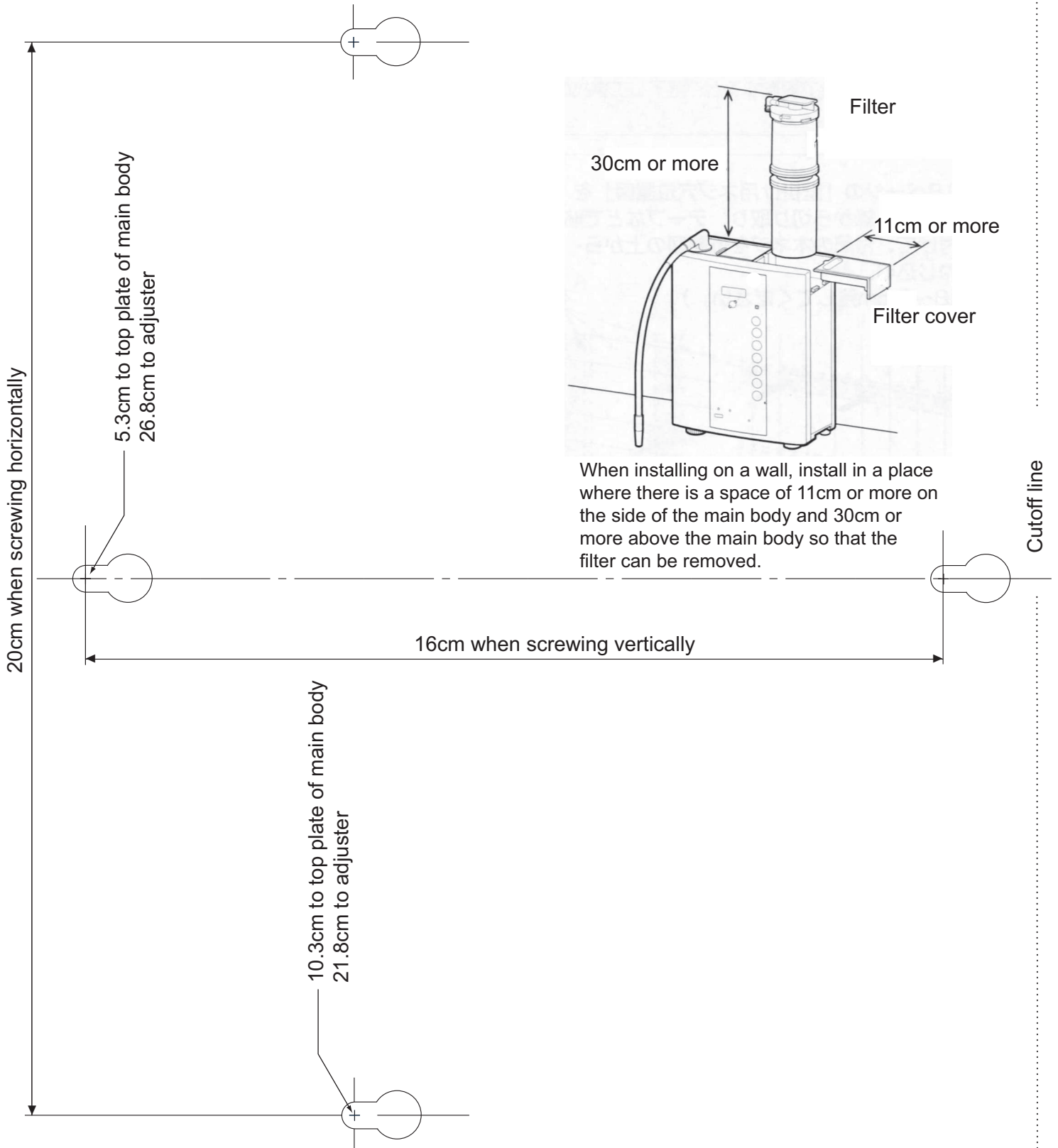

When installing on a wall, install in a place where there is a space of 11cm or more on the side of the main body and 30cm or more above the main body so that the filter can be removed.

# Installation of delivery pipe

## ⚠ CAUTION



Prohibited

Do not extend the water outlet with a hose. (Water leakage and failure may result.)

Do not unnecessarily screw in because the inserting part is made of plastic. (Water leakage and failure may result.)

### Note

- When bending the delivery pipe after installation, hold the root and bend the pipe with your free hand.

Installation of this part.

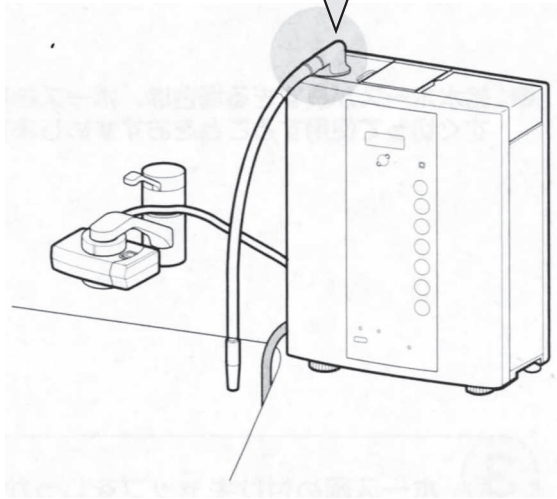

Screw in the delivery pipe to the root.

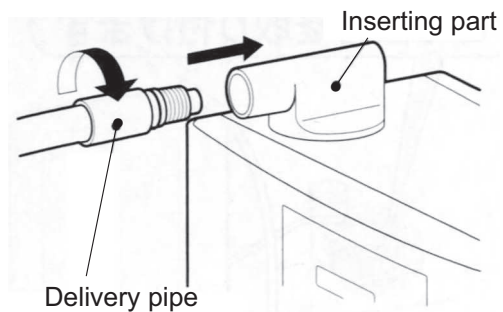

# Installation of drain hose

### Note

- The difference in height between the end of the delivery pipe and the end of the drain hose shall be 15cm or more, and less than 40cm. (In order to obtain the appropriate pH value)
- Set the end of the drain hose below the bottom face of the main body.
- If the drain hose is excessively long, cut it for use.
- Prevent the drain hose from being bent.
- Do not extend the drain hose.

Fix the drain hose to a sink with a suction cup.

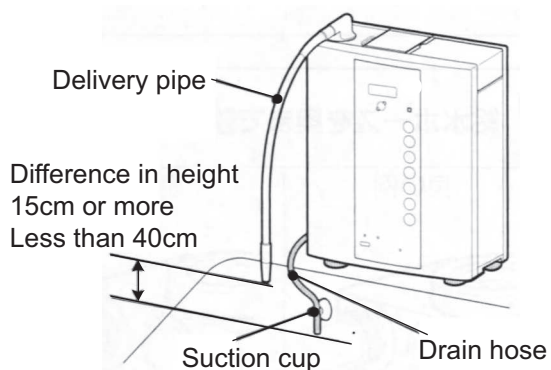

# Connection of water supply hose

## ⚠ CAUTION



Prohibited

Do not bend or twist the water supply hose. (Water leakage may result.)

Do not install to water tap dedicated to hot water. (Failure may result.)

When connecting to a combination tap, do not pass hot water (35°C or higher). (Failure may result.)

### Note

- When installing the corporation stop to a water tap, set the water supply hose to be flexible so as to allow the water tap to swing to both sides.

### Installation of this part.

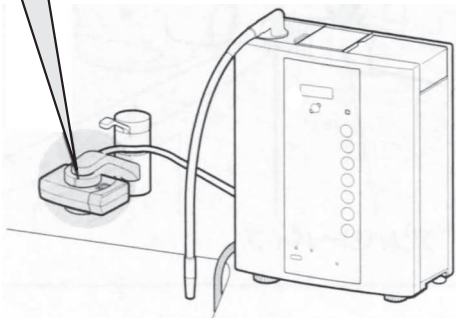

- If the water supply hose is excessively long, it is recommended to cut the hose straight for use.

1

Remove the hose tightening cap from the corporation stop and pass it through the water supply hose. (①)

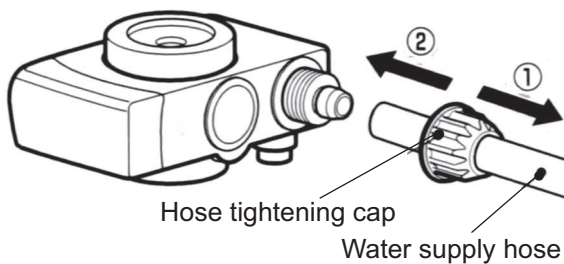

3

Firmly tighten the hose tightening cap.  
• Do not use any tools.  
(Breakage of corporation stop may result.)

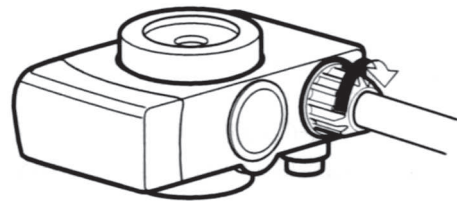

2

Insert the water supply hose all the way. (②)

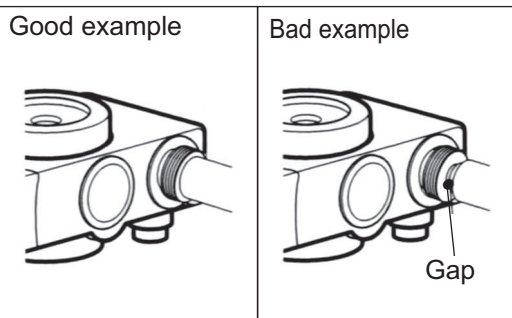

4

Fix the water supply hose with the hose fixing band.  
• Do not crush the hose when fixing.

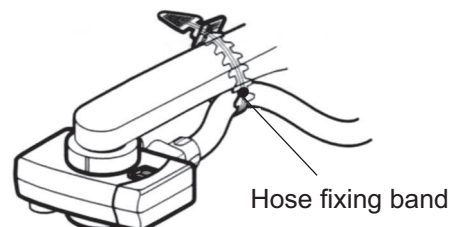

## Make sure to carry out when passing water for the first time after installation.

- Remove the filter cover to confirm that a filter is installed.
- Pass water once before inserting the power plug into the power outlet.

**1** Set the ionized water, purified water and tap water selection lever to the “ionized water, purified water” side and open the cock of tap water.

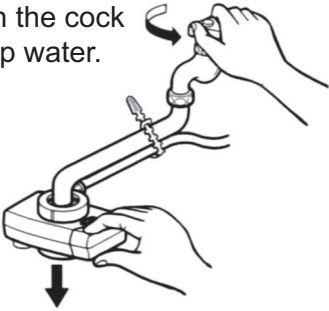

**2** Pass water until the water becomes transparent.

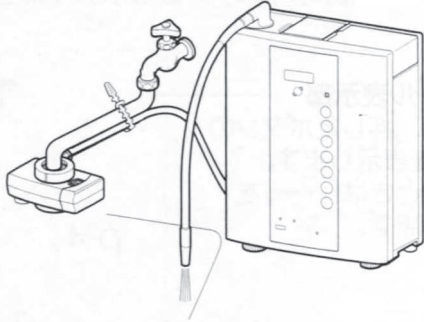

- When water comes out from the pressure valve of the corporation stop, choke the tap water cock because water pressure is excessively high.
- When water does not come out, confirm that the ionized water, sanitized water selection lever has been completely switched.
- When switching the corporation stop lever, make sure to stop water. (Failure may result.)

## Using alkaline ionized water, acid water and purified water

continued

### ⚠ CAUTION



Prohibited

Do not use while the digital display flashes.

- The digital display continuously flashes until retained water in the main body is completely flowed.
- Flashing time depends on use interval or flow rate.

### Note

- As water becomes turbid immediately after water supply work has been carried out, set the selection lever of the corporation stop to the “tap water” side and wait to use until the water becomes transparent. (Clogging of the filter may result.)
- Do not use with the power plug removed from the power outlet. (Because flow rate for judgment of filter life and number of operating days cannot be counted, there may occur an error in filter replacement time.)

**1** Insert the power plug into the power outlet and press the pH adjustment button to be used.

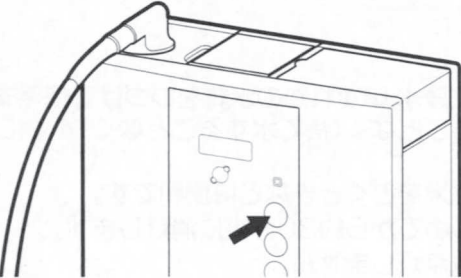

**2** Set the selection lever to the “ionized water, purified water” side and open the cock of tap water.

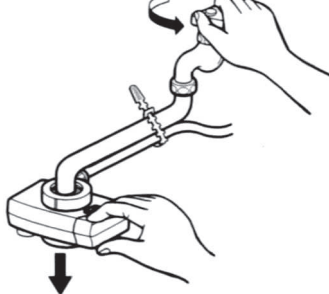

# Using alkaline ionized water, acid water and purified water

3

Use after the digital display changes from flashing to lit and the buzzer sounds.

- Water does not come out from the drainage hose while “purified water” is used.
- After “strong alkaline ionized water,” “acid water” or “sanitized water” is used, and is stopped once and then used again, the water automatically returns to the previously used drinking alkaline ionized water or purified water in order to prevent improper drinking.
- The alarm buzzer keeps sounding when “strong alkaline ionized water,” “acid water,” or “sanitized water” is used.

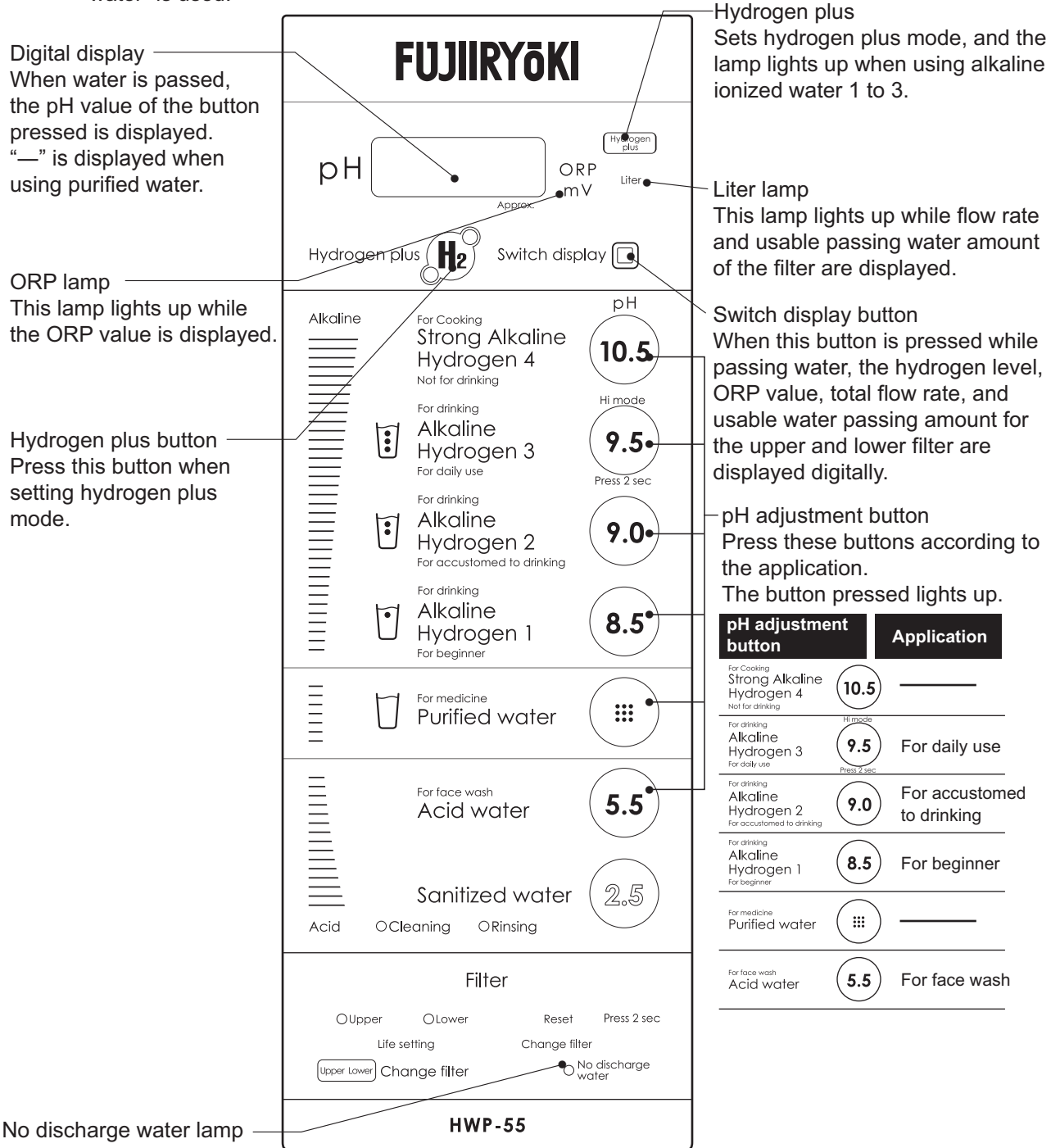

No discharge water lamp

While this lamp is lit, immediate use is possible because there is no discharge water when continuously using any water quality of alkaline ionized water 3, 2, or 1 or purified water that was previously used. This is convenient for continuously drinking alkaline ionized water or washing rice, etc.

This is convenient for continuously drinking alkaline ionized water or washing rice, etc.

- The “No discharge water lamp” turns off after about 30 minutes when (Alkaline ionized water) is switched to (Purified water) or the tap water cock is closed.
- This lamp does not light up when “Alkaline ionized water” or “Acid water” is selected.

### Alkaline ionized water

Press the alkaline hydrogen button or strong alkaline hydrogen button to use the “alkaline ionized water” that comes out from the delivery pipe.

### Acid water

Press the Acid button to use the “Acid water” that comes out from the delivery pipe.

- Water that comes out from the drain hose cannot be used because it is highly alkaline.

#### Note

- Acid water of a pH lower than the indicated pH value may come out if the water amount is extremely choked\* when “Acid water” is used.

Although digital display indicates a standard value of pH5.5, check with a pH measuring liquid.

\*Extreme water amount means a flow rate of about 1.5L/minute at the discharge port or a flow rate which takes about 6 seconds to fill one cup as a rough standard.

#### Information

The digital display flashes when the flow rate for using “Strong alkaline ionized water and “Acid water” is excessively large. In this case, slowly choke the water tap cock until the lamp changes to lit.

4

Tighten the cock of tap water and set the corporation stop selection lever to the “Water tap” side after use.

- When water is stopped, the usable passing water amount of the rough standard for filter replacement is displayed on the digital display part for 20 seconds in the order of “Upper” → “Lower” for 20 seconds, and then turns off. During digital display, “Upper” or “Lower” lamp on the lower part of the operation panel flashes to inform which passing water is displayed.

<Example of display>

Upper part of operation panel →



Lower part of operation panel →

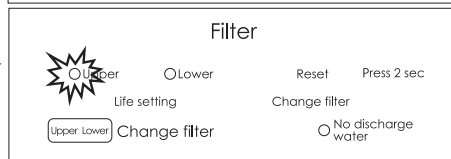

(When service life is set at 16,000L)

- All lamps turn off in about 30 minutes after water is stopped, and power off mode is set. This mode is reset by pressing a button again or passing water.

# When pH value of alkaline ionized water is low

Measure the pH value of alkaline ionized water according to the “Measure pH value” on page 30 after installation.

When the measured value is lower than the pH value of the main body (refer to “Information” on page 30)

- Use it as is when the pH value is low due to influence of carbonic acid in the tap water.
- When the pH value is low due to water quality, set to the “Hydrogen plus mode” or “Hi mode.” The pH value of “Alkaline 1, 2, or 3” can be increased.  
Set to “Hi mode” if the pH value does not reach the rough standard range even when “Hydrogen plus mode” is set.

※The amount the pH value increases depends on water quality and operating conditions.

## Information

- The digital display continuously flashes if the flow rate is excessively large when “Hi mode” is set. In this case, slowly choke the water tap cock until it changes to lit.
- The pH value does not change when using “Strong alkali,” “Acid water,” or “Sanitized water” even if “Hydrogen plus mode” or “Hi mode” are set.
- There is a method to increase pH value by adding a option electrolysis auxiliary. Add the electrolysis auxiliary according to “Addition of electrolysis auxiliary” on page 37.

### Set Hydrogen plus mode

- … Press the “Hydrogen plus” button without passing water. The Hydrogen plus lamp lights up, and flashes when starting to pass water. The “Hydrogen plus” button does not accept when “Strong alkali,” “Purified water,” “Acidic water” or “Sanitized water” are set.

### Cancel Hydrogen plus mode

- … Press the “Hydrogen plus” button without passing water. The Hydrogen plus lamp turns off.

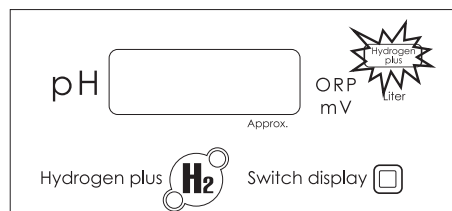

← This indicates that Hydrogen plus mode is set.

### Set Hi mode

- … Hold the “alkaline hydrogen 3” button (2 seconds or longer) without passing water. When starting to pass water, “Hi” and the set pH value are displayed on the digital display.

### Cancel Hi mode

- … Hold the “alkaline hydrogen 3” button until a sound is heard (2 seconds or longer) without passing water. When starting to pass water, only the set pH value is displayed on the digital display.

For drinking  
Alkaline  
Hydrogen 3  
For daily use

For drinking  
Alkaline  
Hydrogen 2  
For accustomed to drinking

For drinking  
Alkaline  
Hydrogen 1  
For beginner

Hi mode  
9.5

Press 2 sec.

9.0

8.5

“Hi mode” setting button

<Example of display>



“Hi” being displayed indicates that Hi mode is set.



# Observing hydrogen level

When the switch display button is pressed once while alkaline ionized water 1, 2, or 3 is generated, the hydrogen level is displayed on the digital display part.

※ The rough standard for hydrogen generation amount is displayed. (This is not displayed while water is stopped and while “Strong alkali,” “Purified water,” or “Acid water” are used and when “Hi” mode is set.)

The display returns to pH value when the “Display selection button” is pressed 4 times while water is passed.

“H2L” is indicated when displaying the hydrogen level.

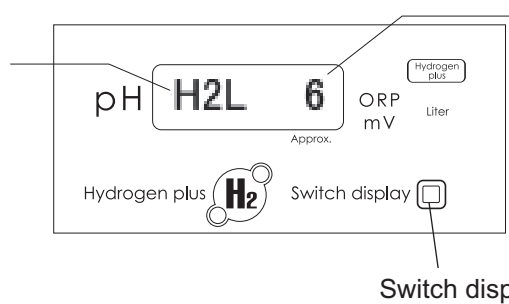

The hydrogen generation amount is displayed with a number from 1 to 6. The number increases with a larger hydrogen generation amount.

# Observing ORP value

When the “Display selection button” is pressed 2 times while Alkaline ionized water 1, 2, or 3 is used, or is pressed once while “Strong alkali,” “Purified water,” or “Acid water” are used, the ORP value\* (rough standard) for generating water is displayed on the digital display part.

\* The ORP value is a value that was estimated under predetermined conditions. It is not the actual measured value of the actual generated water. (It may be different from the actual numerical value depending on water quality.)

The display returns to pH display when the “Switch display” button is pressed 3 times while water is passed.

- This is not displayed while water is stopped and “Purified water” is used.

<Example of display>

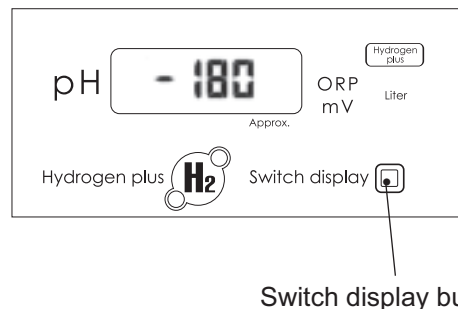

Switch display button

# Observing flow rate

When the “Switch display” button is pressed 3 times while Alkaline ionized water 1, 2, or 3 is used, or is pressed 2 times while “Strong alkali,” “Purified water,” or “Acid water” are used, or is pressed 1 time while “Purified water” is used, the flow rate is displayed on the digital display.

※ Flow rate is the total amount of water coming out from the discharge port and drainage hose. The display returns to pH display when the “Display selection button” is pressed 2 times while water is passed.

<Example of display>

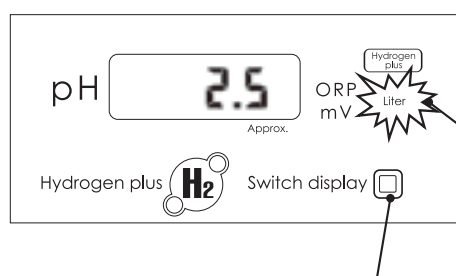

Liter lamp  
The “Liter” lamp lights up while flow rate is displayed.

Switch display button

# Observing filter life

The usable passing water amount that serves as a rough standard for filter replacement and the number of usable days are displayed on the digital display.

## Filter life display

- For the usable passing water amount that serves as a rough standard for replacement, the remaining amount is displayed in the 1L (liter) units.  
(16,000L for the purpose of residual chlorine processing capacity)
  - ※ The numerical value decreases every time water is passed.
- The number of usable days is also displayed 14 days before the 730 day (2 year) maximum rough standard for filter replacement.
  - ※ Standby time is also counted and displayed as a number of days. An error occurs if the power plug is removed.

<Example of display>

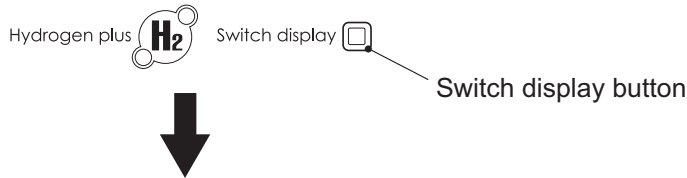

## How to check service life

① Press the switch display button while water is stopped.

<Example of display>

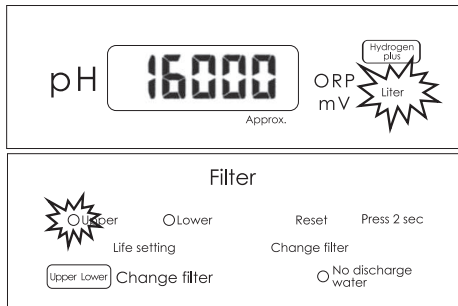

(Example) When 16,000L is set

② The usable passing water amount for the "Upper, Lower" filters is displayed. The remaining amount is displayed on the digital display part in the order of "Upper" → "Lower" for 3 seconds.

- ※ When the upper filter is displayed, "Upper" on the lower part of the operation panel flashes, and when the lower filter is displayed, "Lower" flashes.

## ● 14 days before the rough standard for filter replacement (maximum 730 days)

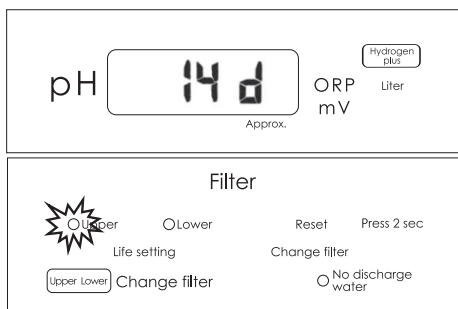

<Example of display>



(Example) When 14 days are remaining

After the passing water amount is displayed, the number of usable remaining days is displayed in the order of "Upper" → "Lower."

## Sanitized water: Cleans the passage for water passing.

⚠ CAUTION	
 Prohibited	Never drink sanitized water because it is a strong acid water of about pH2.5. (Poor physical condition may result.)
	When feeling any abnormality with your body by using sanitized water, immediately stop using and consult with a doctor.
	Do not store sanitized water. (Generated chlorine may result in poor physical condition.)
	Do not soak metallic dishes or rings in sanitized water. (Rust and discoloration may result.)
 Make sure to observe	When generating, using or draining sanitized water, use in a well-ventilated place by turning on a ventilation fan or opening a window because a chlorine odor occurs. (Poor physical condition may result.)
	If sanitized water or water coming from the drainage water hose gets into your eyes, immediately rinse eyes out with tap water.
	After generating, using or draining sanitized water in a stainless steel sink, rinse out sink with tap water. (Discoloration of sink may result.)
	When sanitized water splashes on clothing or hair, rinse clothing or hair off with tap water. (Discoloration may result.)

**1** Tighten the cock of water tap and then open the top cover.

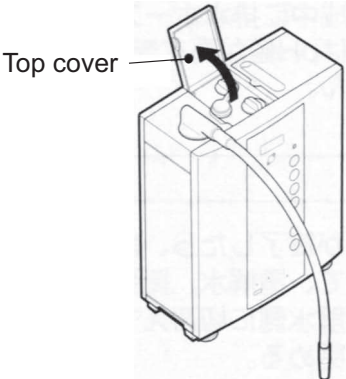

**2** Turn the salt cap counterclockwise and take out the salt case.

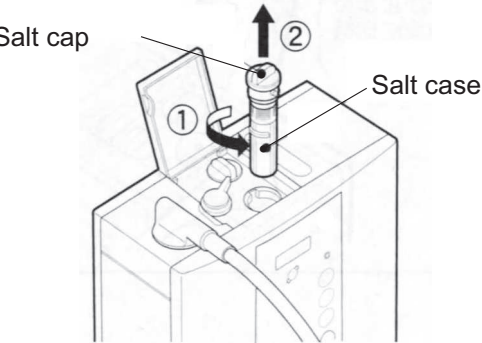

**3** Pull out the salt cap.

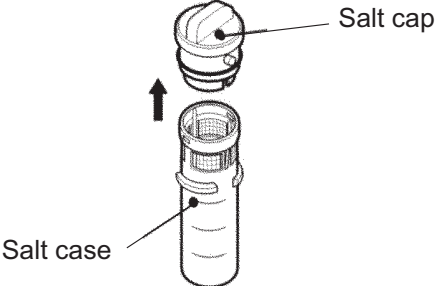

**4** Put the included salt into the salt case, and mate the groove of the salt cap with the convex of the salt case.

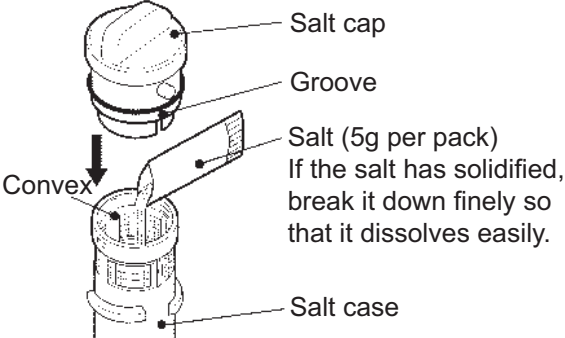

Put in an amount of included salt that corresponds to the amount of sanitized water to be generated. Refer to the "Amount of salt and rough standard for sanitized water generation amount" on page 29 as a rough standard.

How to use

# Generation of sanitized water

- 5** Insert the salt case into the main body and firmly turn the salt cap clockwise to install.  
(Insufficient installation causes water leakage.)

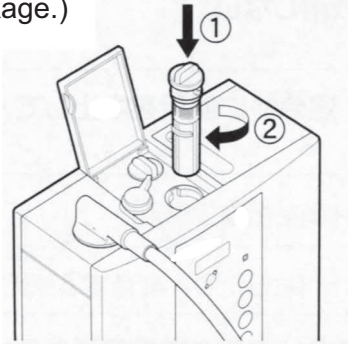

- 6** Set the Ionized water, sanitized water selection lever to the "Sanitized water" side.

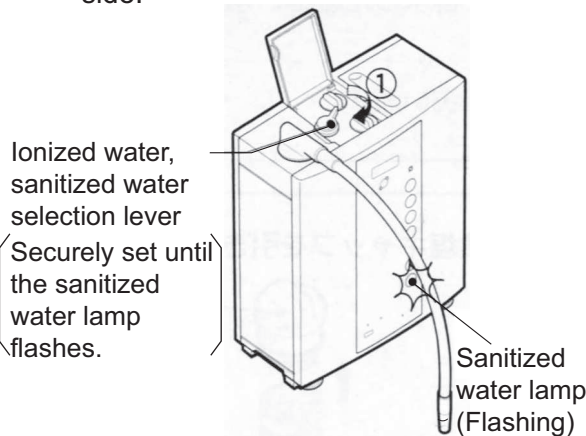

- 7** Open the cock of water tap. The digital display flashes for about 3 seconds, and then "Sanitized water" is generated. The digital display changes to lit during generation.

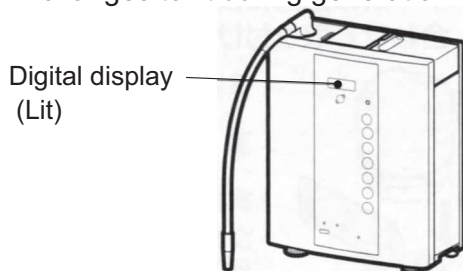

<If the digital display does not change to lit>

- There is no salt in the salt case.  
Put salt into the case.
- The salt is solidified and has not dissolved.  
Replace the salt.

- 8** If salt runs out after generation of "Sanitized water," rinsing is automatically carried out for about 30 seconds. Do not tighten the cock of water tap. Water during rinsing is not sanitized water.

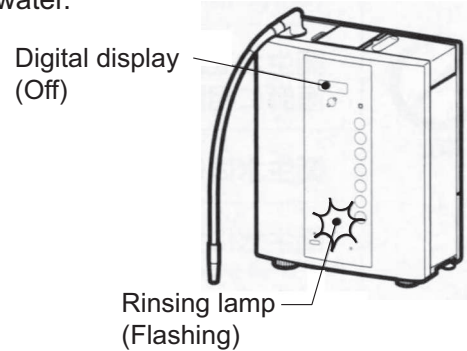

- An alarm sounds during generation of "Sanitized water" and rinsing.
- When "Ionized water" and "Purified water" are generated by setting the Ionized water, sanitized water selection lever to the "Ionized water" side without rinsing, do not use until the digital display part lights up in order to flow the remaining salt in the water passage.
- Other "Ionized water" and "Purified water" cannot be used while the Ionized water, sanitized water selection lever is set to the "Sanitized water" side.
- Alkaline ionized water coming out from the drain hose during generation of sanitized water cannot be used because its pH is excessively high.

- 9** When rinsing is completed, tighten the cock of water tap, set the Ionized water, sanitized water selection lever to the "Ionized water" side, and close the top cover.

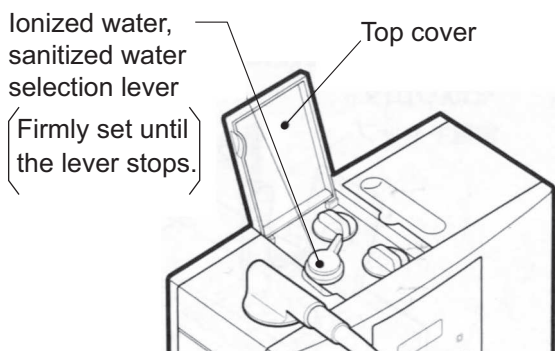

## Usable salt

Sodium chloride or salt with a salt content of 99% or more can be used in addition to the attached salt.

## Amount of salt and the rough standard for sanitized water generation amount

Use the scale on the salt case as a rough standard, and put in salt (sodium chloride or salt with a salt content of 99% or more) according to the amount of sanitized water to be generated.

- If an excessive amount of salt is put in, the remaining salt in the case solidifies, and sanitized water may not be generated.

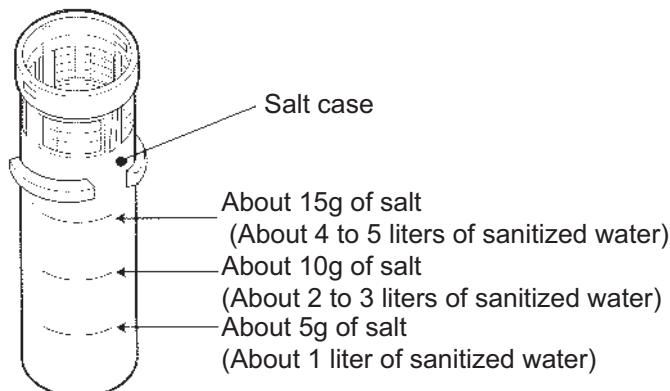

## When salt has solidified

If salt is left in the salt case, the salt solidifies and will not dissolve when sanitized water is generated, and sanitized water may not be generated.

(Even when salt is put into the salt case, the digital display remains flashing and sanitized water cannot be generated.)

Wash out the solidified salt with tap water, and put new salt into the salt case.

## When “Sanitized water” is used, the digital display flashes if the flow rate is excessively large.

In this case, slowly choke the cock of tap water until the display changes to lit.

# Precautions for use

- When using in areas where hardness of water quality is high\*, pass acid water for about one minute at the beginning of daily use. (Because calcium adheres to discharge port and water channel to cause water to poorly come out)

※ Areas where hardness of water quality is high: Soap foams poorly and white matter (calcium) adheres to kettles and pans.

- Do not pass well water containing salt such as seawater (well water close to the shore).  
 ※ The “Rinsing lamp” flashes and alkaline ionized water may not be generated.

- Do not hold the delivery pipe or filter to lift up the main body. (Breakage may result)

# Measuring pH value

## ⚠ CAUTION



Prohibited

Do not drink pH test liquid or water containing pH test liquid, or do not put into eyes. (In particular, pay close attention to children.) Poor physical condition may result.

- If you accidentally drink pH test liquid, drink a large amount of water and seek medical attention.
- If you accidentally get pH liquid into your eyes, sufficiently wash with water and seek medical attention.
- Make sure to cover with a lid and store in a cool and dark place away from infants.



Keep fire away

Do not bring pH test liquid close to fire because it contains alcohol. (Fire may result)

- After installation and if not used for a long time (one week or longer as a rough standard), make sure to measure pH value with the included pH test liquid, and confirm that alkaline ionized water 3 (pH value of 9.5 as a rough standard) does not exceed pH10 before use. Periodically measure it after that (more frequently than once a month).
- Flow alkaline ionized water for 5 seconds or longer after the digital display changes from flashing to lit, and take in the included dedicated cup. (in order to measure stable pH)

1

Put alkaline ionized water in the dedicated cup and rinse 2~3 times, and then put it up to the scale.

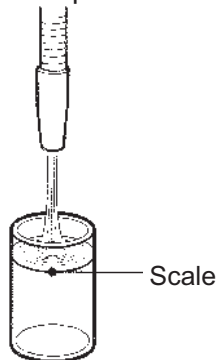

3

Compare the color of the colored water with the color of pH test color paper, and the numerical value of the same color is the pH of the alkaline ionized water.



pH test color paper

2

Put one droplet of pH test liquid in the generated water and slightly shake the cup.

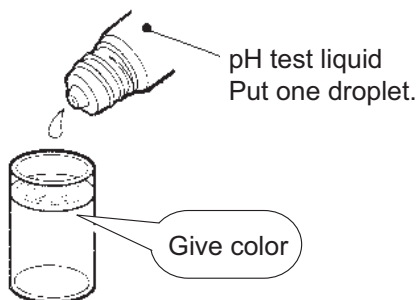

### Information

- When using an underground water source for tap water in some regions, the tap water may contain a large amount of carbonic acid. The selected pH value may not match the pH value of the pH test liquid due to the influence of this carbonic acid. To confirm whether carbonic acid is contained or not, refer to the cause and measures in “Alkaline ionized water does not change to blue or dark blue even with testing with pH test liquid” on page 39.
- The pH value of alkaline ionized water may not increase depending on water quality. In this case, take either of the following measures.
  - Set to “Hydrogen plus mode” or “Hi mode.” (Refer to page 24)
  - Add an electrolysis auxiliary. (Refer to page 37)
- When the pH value is high, take either of the following measures.
  - Change to weakly alkaline mode.

### Note

- Color of the test water changes as time passes. Compare it with pH test color paper immediately.
- When disposing of raw liquid of pH test liquid, dilute it with water and discharge it to sewage.
- Since pH test liquid and pH test color paper are discolored when exposed to sunlight, store them in a dark place.

# Cleaning inside of the main body

- In order to remove calcium adhering to the electrode plate in the main body and keep the generating function, the electrode plate is automatically cleaned.

When the total water passing amount of “alkaline ionized water” and “strong alkaline ionized water” exceeds about 10 liters



Close the cock of water tap. Or set the Ionized water, purified water, tap water selection lever to the “tap water” side.



After about 30 minutes



The electrode plate is automatically cleaned.  
(for about 40 seconds)  
The “Cleaning lamp” flashes during cleaning.  
After cleaning finishes, the “Cleaning lamp” turns off, and the cleaned water comes out from the drain hose.

For face wash  
Acid water

5.5

Sanitized water

2.5



○ Cleaning    ○ Rinsing

Cleaning lamp



When water is passed after automatic cleaning ends, generation is started after the cleaned water is discharged.

※ The digital display and Cleaning lamp flash and the buzzer sounds (about 6 seconds) while the cleaned water is discharged.  
Do not use.

- The service life of the electrolysis tank in the main body is about 1,100 hours.  
(Time when the electrode is powered)  
However, the service life depends on operating conditions and water quality.

## Note

- Do not use water which comes out from the drain hose after electrode automatic cleaning.  
(Water comes out for about one minute.)
- If water is passed during automatic cleaning, discard the water until the digital display changes from flashing to lit.

# Maintenance

## ⚠ CAUTION



Keep dry

Do not splash water on or wash the main body.  
(Electric leakage or electric shock may result.)

Moisten a soft cloth with water or diluted kitchen detergent (neutral) and firmly squeeze it to wipe off contamination on the main body and corporation stop.

### ● Maintenance of corporation stop

If contaminants have accumulated in the metal mesh of the corporation stop, the metal mesh will clog and the water amount will decrease. When the water amount of “ionized water, purified water”, “tap water shower” or “tap water straight” has decreased or if used for a long time (6 months or longer), disassemble the corporation stop and remove contaminants which have accumulated in the metal mesh and shower part with a toothbrush or the like.

- Be careful not to lose parts when disassembling.
- When assembling, refer to the diagram so as not to confuse the assembly order.

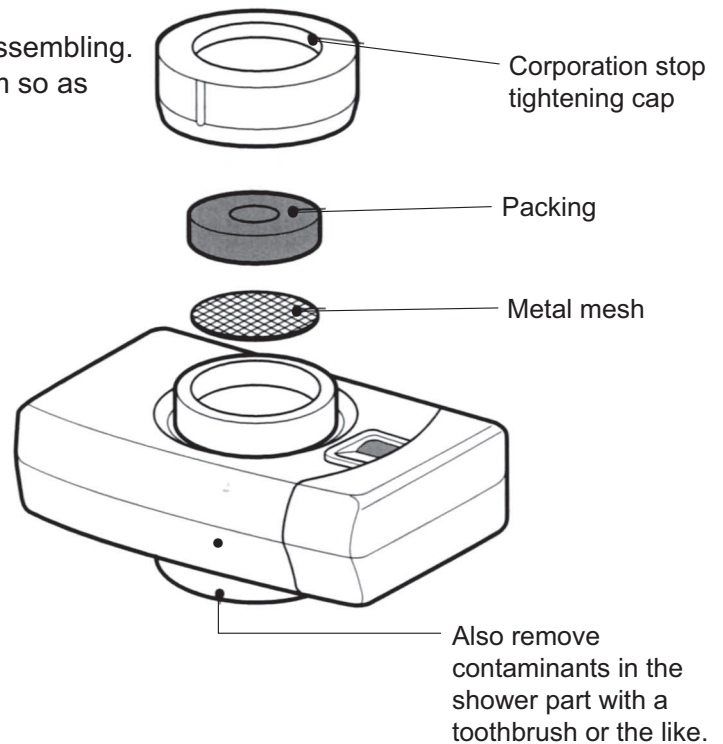

## Anti-freezing

Note

Drain water in seasons when tap water freezes in cold regions because water retained in the main body and water supply hose may freeze, resulting in breakage of the main body and hoses.

- 1 Set the ionized water, purified water, tap water selection lever to the “tap water” side.
- 2 Remove the water supply hose from the corporation stop, and put in a place lower than the main body to drain water.
- 3 Thermally insulate the main body with a towel or the like, or put in a warm place.

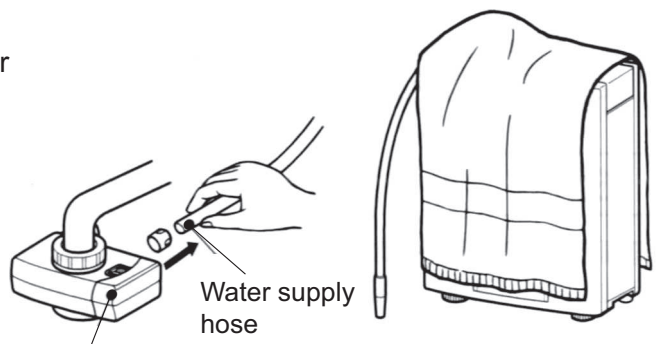

Set the ionized water, purified water, tap water selection lever to the “tap water” side.



## ■ Filtering performance of filter

Product No.		Filtering material	Removable substance
FW-13CM (Set product)	FW-02C (Upper filter)	Hollow fiber film	Fine particles of 0.1 micrometer or smaller (such as saprophytic bacteria, red rust)
	FW-11M (Lower filter)	Nonwoven fabric	Coarse contaminant
		Granular active carbon	Free residual chlorine, total trihalomethane, soluble lead, CAT (agricultural chemicals), 2-MIB (moldy odor), tetrachloroethylene
Fibrous active carbon			

## ■ Rough standard for filter replacement

- Usable passing water amount: 16,000L (intended for residual chlorine processing capacity)
- Operating period: Maximum 730 days (about 2 years)

Rough standard for filter use

- If 40 liters are used per day About 1 year
- If 20 liters are used per day About 2 years

The rough standard for use depends on your water quality.

If you are concerned about an odor or if the water amount significantly decreases, consider that it is time to replace the filter.

[Note] Even if the usage amount is small, replace the filter in a maximum of 2 years.

## ■ Time for filter replacement

The time for filter replacement is indicated for “Upper, Lower” respectively by the digital display and filter replacement lamp.

When the filter replacement lamp lights up, the buzzer sounds to inform replacement is necessary after use.

- Buzzer sound informing filter replacement

When it is time to replace the filter, the filter replacement lamp lights up and the buzzer sounds to inform replacement is necessary after every use. This buzzer to inform that replacement is necessary can be stopped by holding the display selection button for 2 seconds or longer when the buzzer sounds. When returning to the replacement informing state by the buzzer, remove the power plug from the power outlet once and insert again.

※ Pressing the reset button after replacement of the filter returns to the replacement informing state by the buzzer.

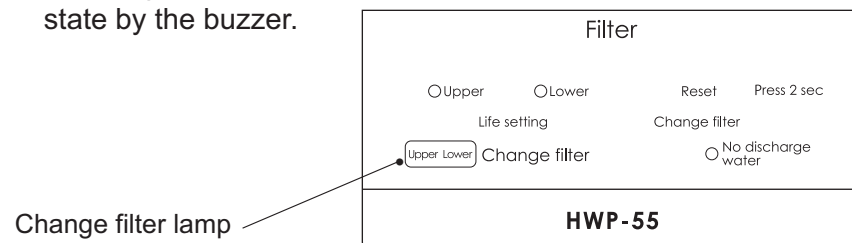

	Digital display		
Usable passing water amount	561 liters or more	561 liters or less	0 liters
Number of usable days	15 days or more	14 days or less	0 days
Filter replacement lamp	Off	Flashing (*1) It is almost time to replace. Prepare for replacement.	Lit (*2) Please replace the filter

\*1 The lamp flashes while water is passed and for about 30 minutes after water is stopped.

\*2 The lamp is always lit while water is passed and during standby.

# Filter replacement

## Information

The filter becomes quickly clogged in the following cases.

- Operating time significantly depends on content and turbidity of organic substances.
- Well water may decrease the service life of filters.
- Total usage amount in a day indicates water amount flowing through the filter, therefore, it is the amount of both of electrolysis water and drainage water.
- If particles (turbidity and invisible clogging components) and organic substances are contained in water, water amount may significantly decrease.
- If turbid water and red rust water are mixed into the main body due to water service work, the filter will clog and the water amount will decrease regardless of usage time. Replace the filter in this case as well.

Discharge rate may decrease in the following cases.

- Water temperature is low.  
(Water viscosity increases and it is difficult for water to pass through the filter.)
- Use in a place where water pressure is low (such as the top floor of a building)
- Tap water pressure always changes depending on the local tap water operating state, and water amount may decrease depending on the time of day used.

## When simultaneously replacing upper and lower filters

- 1** Tighten the cock of water tap and open the filter cover.

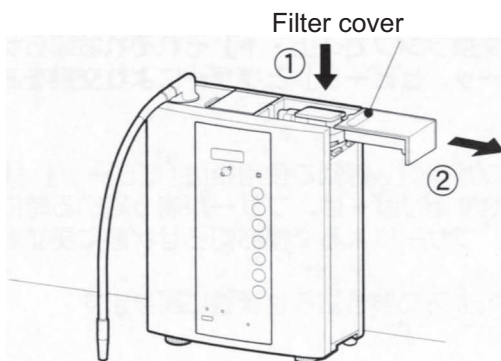

- 2** Hold the filter cap and pull the filter out upward.  
If the filter is difficult to pull out, wiggle it back and forth to pull it out.  
(Note that water comes out from the bottom of the filter.)

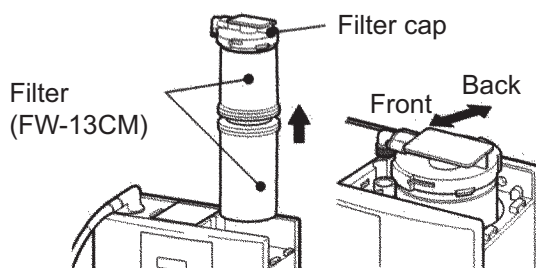

- 3** Turn the filter cap counterclockwise and remove the upper filter first.  
Do not lose the filter cap because it is installed on the newly set filter.

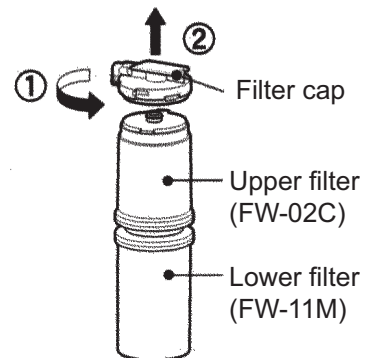

### <Note>

If water comes out from the filter when pulling out the filter and enters the main body, the water will come out from the drainage hole at the bottom of the main body. Wipe up the drained water. The product can be used as is.

**4** Install the filter cap to a new filter.

Filter cap

Filter

Mark

Click

Mate the mark on the filter with the mark on the filter cap. (Click sound is made.)

**6** Close the filter cover, set to purified water mode, and pass water until the water that comes out becomes transparent (for 2~3 minutes). A small amount of black powder from the active carbon in the filter may come out. (If water is passed without closing the filter cover, the filter will float and water leaks.)

Purified water mode

Filter cover

**5** Install the filter to the main body. Make sure to securely insert all the way.

Filter

Filter cap

Main body

Packing

Hole

Mate the packing on the filter cap with the hole on the main body.

**7** Press the filter change reset button for 2 seconds or longer.

The buzzer sounds and the change filter lamp turns off.

Filter

Upper Lower Change filter

Life setting

Reset Press 2 sec

No discharge water

The lamp turns off. Press for 2 seconds or longer.

**When replacing only upper or lower filter**

**4** Turn the filter in the arrow direction to pull out in a kitchen sink. A large amount of water comes out from the filter.

Upper filter (FW-02C)

Lower filter (FW-11M)

**5** Install a new filter. Turn it to a position where the mark on the upper filter mates with the mark on the lower filter. (Click sound is made.)

Upper filter (FW-02C)

Lower filter (FW-11M)

Mark

Click

# Filter replacement

- 6** Install the filter to the main body and pass water until the water that comes out becomes transparent (for 2~3 minutes) with reference to (4) through (6) in “When simultaneously replacing the upper and lower filters” on page 35.

**7** <This illustration shows replacement of the upper filter.>

- ① Press** 

Digital display part

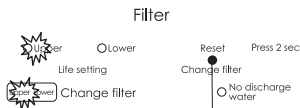
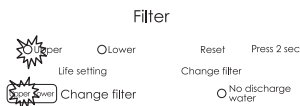

- ③ Press for 2 seconds or longer**

- ①** Press the filter life setting button (“Upper” or “Lower”) of the replaced new filter.



- ②** The change filter lamp of the pressed button flashes, and filtering capacity of the filter currently being set flashes on the digital display part. This flashing number on the digital display part changes every time “Upper” or “Lower” on the filter life setting button is pressed.



- If “16000” is set, you will be informed that replacement is required when 16,000 liters are used. (\*Normally use with this set at “16000.”)
- If “5500” is set, you will be informed that replacement is required when 5,500 liters are used.
- If “3000” is set, you will be informed that replacement is required when 3,000 liters are used.



- ③** Press the change filter reset button for 2 seconds or longer while the filter life setting lamp flashes (about 8 seconds). The buzzer sounds, and the digital display, filter life setting lamp and change filter lamp turns off. If reset cannot be completed while the filter life setting lamp flashes, perform from ① again.

## If you are concerned about trihalomethane etc.

- If you are concerned about trihalomethane etc., in tap water, decrease the service life setting of the lower filter and replace as soon as possible.

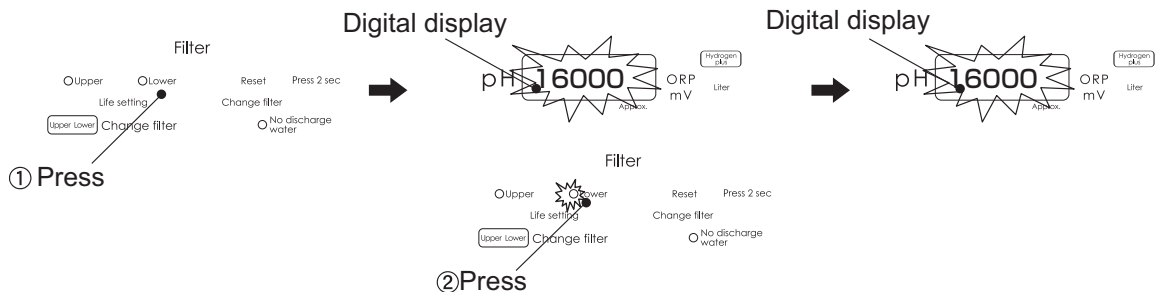

Press “Lower” on the filter life setting button to change the number on the digital display to “5500” and wait until the filter life setting lamp lights off (about 8 seconds). The water amount starts from the passed water up to that time, and when it gets close to the newly set life, the change filter lamp flashes. (If the water amount has already flowed more than the set life, the change filter lamp lights up.)

- Foam may be mixed in with ionized water and purified water, and the water amount may decrease after replacement of the filter. This is because air in the filter has not been extracted, and it will return to normal after water has passed for a while.

# Addition of electrolysis auxiliary (calcium glycerophosphate)

Some water qualities may interfere with electrolysis and pH value does not increase. To facilitate electrolysis, use the optional calcium case or electrolysis auxiliary (calcium glycerophosphate).

Calcium case  
(not attached with  
this product)

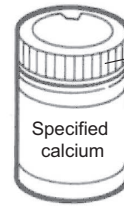

Electrolysis auxiliary  
(not attached with this  
product)

- When adding electrolysis auxiliary (calcium glycerophosphate), do not directly put in calcium into the main body of the product without the optional calcium case (page 37 in the Instruction Manual). (Failure may result.) If you directly put in calcium, pass water until calcium does not come out.
- **Make sure to close the tap water cock to add.**

- 1** Open the top cover, turn the calcium cap counterclockwise and take out the calcium case.

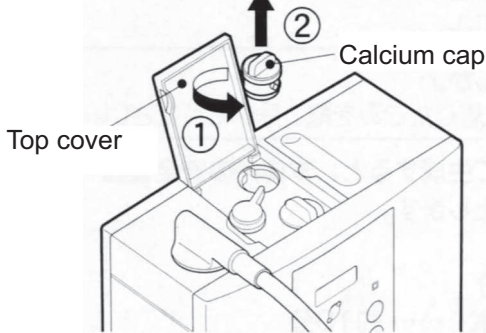

- 3** Install to the calcium cap.

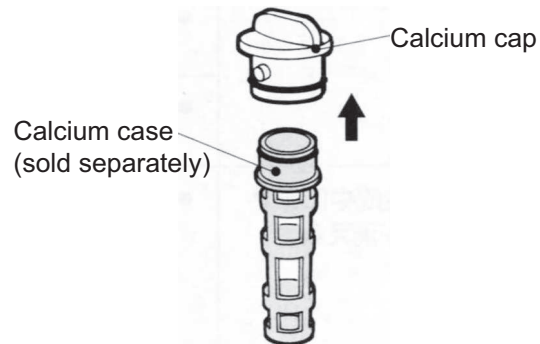

- 2** Put calcium glycerophosphate into the calcium case (option) with a spoon for addition.

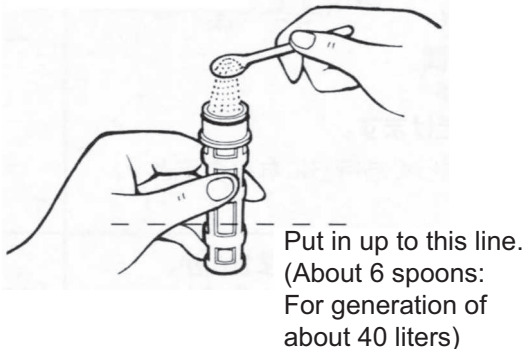

- 4** Insert the calcium case into the main body, and firmly turn the calcium cap clockwise to install. (Insufficient installation may result in water leakage.)

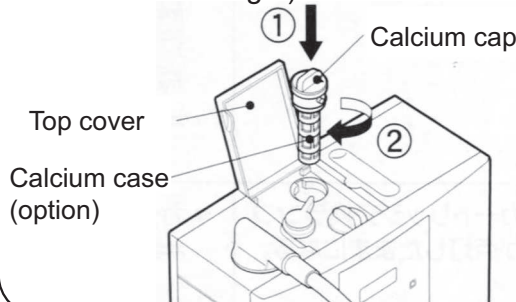

## Note

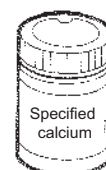

- Use only the specified electrolysis auxiliary.
- Make sure to observe the additive amount of the electrolysis auxiliary.
- When not using for a long time (about one week or longer), completely remove the remaining electrolysis auxiliary.
- Clean the calcium case and calcium cap once a week.  
When the calcium case becomes unsanitary, fungus may grow.
- How calcium dissolves depends on water quality, water temperature and operating conditions.
- When purchasing the specified electrolysis auxiliary, contact the store where you purchased this product.



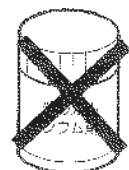

Specified  
electrolysis auxiliary

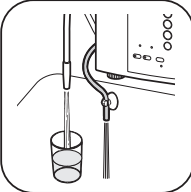

# When failure is suspected

	In such a case	Possible cause and measures	Reference page
Indication	Nothing is indicated (lit).	<ul style="list-style-type: none"> <li>● Is the power plug removed from the power outlet? ⇒ Securely insert the power plug all the way.</li> </ul>	11
		<ul style="list-style-type: none"> <li>● The lamps automatically go off when not in use because of the power off mode. ⇒ This is not a failure. ※ All lamps go off when not used for 30 minutes or longer after water is stopped.</li> </ul>	23
	Nothing is displayed digitally.	<ul style="list-style-type: none"> <li>● Is the filter clogged? ⇒ Time when the filter is clogged significantly depends on water quality of tap water (such as turbidity, iron rust). Replace the filter.</li> </ul>	33 { 36
		<ul style="list-style-type: none"> <li>● Has the water pressure decreased? ⇒ Wait until water pressure has recovered.</li> </ul>	—
		<ul style="list-style-type: none"> <li>● Is the water supply hose bent? ⇒ Correct the bend.</li> </ul>	—
		<ul style="list-style-type: none"> <li>● Is the corporation stop clogged? ⇒ Remove contaminants adhered to the filter in the corporation stop.</li> </ul>	32
	Digital display disappears during generation of ionized water.	<ul style="list-style-type: none"> <li>● If “Ionized water” is continuously generated for the following time, the safety device in the main body operates to stop generation of ionized water. (Water flows.)                             <ul style="list-style-type: none"> <li>● “Alkaline ionized water” --- About 10 minutes</li> <li>● “Strong alkali,” “Acidic water” --- About 5 minutes</li> </ul>                             ⇒ Close the cock of water tap once, wait for about 30 minutes and open again to use.                         </li> </ul>	—
		<ul style="list-style-type: none"> <li>● If the temperature in the main body rises abnormally, the safety device operates to stop generation of “Ionized water.” “□□□□□” flashes on the digital display.   The error indication continues for 10 seconds, and then the “Purified water” lamp automatically lights up. Purified water can be used. ⇒ Tighten the cock of water tap, and it is usable after waiting for a while.</li> </ul>	—
	Change filter lamp remains lit.	<ul style="list-style-type: none"> <li>● Have you forgotten to press the change filter reset button? ⇒ When replacing the filter, press the change filter reset button for 2 seconds or longer.</li> </ul>	35
	Change filter lamp lights up early.	<ul style="list-style-type: none"> <li>● Check usable passing water amount of the filter on the digital display. ⇒ If a large amount of water is used daily, the lamp will light up early.</li> </ul>	26
<ul style="list-style-type: none"> <li>● Is the filter life set to 5,500L or 3,000L? If it is set to 5,500L or 3,000L, the change filter lamp will light up early. (Residual chlorine can be still removed.) ⇒ Check which filter life setting is set.</li> </ul>		36	
“- - -” is displayed on the digital display.	<ul style="list-style-type: none"> <li>● The water is difficult to electrolyze. ⇒ Add the electrolysis auxiliary (option).</li> </ul>	37	

	In such a case	Possible cause and measures	Reference page
Indication	Rinsing lamp flashes.	<ul style="list-style-type: none"> <li>The water passes electricity easily. For protection of the equipment, electrolysis is stopped. ⇒ Set to purified water mode and flow water for a while, and then use.</li> </ul>	29
		<ul style="list-style-type: none"> <li>Does salt remain in the salt case? ⇒ Wash out the remaining salt.</li> </ul>	27 } 28
Generated water	Alkaline ionized water does not become blue or dark blue even when tested with pH test liquid.	<ul style="list-style-type: none"> <li>This is the influence of carbonic acid in tap water. Electrolysis was not performed. Check for carbonic acid by the following methods.</li> <li>(1) Put alkaline ionized water of pH 9.0 into a cup.</li> <li>(2) Put two droplets of pH test liquid into the dedicated cup.</li> <li>(3) Put the alkaline ionized water which was taken in the cup up to the scale on the dedicated cup. If the water becomes blue or dark blue and then immediately discolors to green or yellow, it contains carbonic acid.</li> </ul> <div style="display: flex; justify-content: space-around; align-items: center;"> <div style="text-align: center;">  <p>(1) Put alkaline ionized water into a cup.</p> </div> <div style="text-align: center;">  <p>(2) Put 2 droplets of pH test liquid into the dedicated cup.</p> </div> <div style="text-align: center;">  <p>(3) Put the alkaline ionized water into the dedicated cup.</p> </div> </div>	24 30
	Water does not come out.	<ul style="list-style-type: none"> <li>Is the connection hose, inside of the main body or filter frozen? ⇒ Wait until the water has defrosted.</li> </ul>	32
	Sanitized water cannot be generated.	<ul style="list-style-type: none"> <li>Has salt solidified in the salt case? ⇒ Wash out the solidified salt and insert new salt.</li> </ul>	29
	Amount of generated water and purified water has decreased.	<ul style="list-style-type: none"> <li>Is the ionized water, sanitized water selection lever at a halfway position? ⇒ Securely set the lever.</li> </ul>	11
		<ul style="list-style-type: none"> <li>Is the filter clogged? ⇒ Clogging timing may greatly depend on water quality (turbidity, iron rust) of tap water. Replace the filter.</li> </ul>	33 } 36
		<ul style="list-style-type: none"> <li>Is the corporation stop clogged? ⇒ Remove contaminants adhered to the metal mesh in the corporation stop.</li> </ul>	32
	Abnormal odor occurs.	<ul style="list-style-type: none"> <li>Filter life has expired. ⇒ Replace the filter.</li> </ul>	33 } 36
		<ul style="list-style-type: none"> <li>Are you using water while the digital display is flashing? ⇒ Use water after it changes to lit.</li> </ul>	22
		<ul style="list-style-type: none"> <li>Is the calcium case after addition of electrolysis auxiliary contaminated? ⇒ Clean the case.</li> </ul>	37
	White floating matter appears	<ul style="list-style-type: none"> <li>This is a solid created by a calcium reaction. ⇒ It is not harmful if it is ingested.</li> </ul>	—
Red water (red rust, etc., mixed water) comes out.	<ul style="list-style-type: none"> <li>Rust from the water pipe or turbidity after water supply work is coming out. (Do not drink.) ⇒ Set the ionized water, purified water, tap water selection lever to the “tap water” side, and flow water until red water does not come out.</li> </ul>	—	

# When failure is suspected

	In such a case	Possible cause and measures	Reference page
Generated water	When “alkaline ionized water” is received by a cup, glittery floating matter can be seen or dark brown or black precipitates and floating matter can be seen.	<ul style="list-style-type: none"> <li>● Because of high pH value, components (mainly mineral) which are dissolved in water become hydroxide. (It is not harmful if it is ingested.) ⇒ Decrease the pH value to use.</li> </ul>	22
When generated water is used	Surface of an aluminum kettle or pan is blackened.	<ul style="list-style-type: none"> <li>● When alkaline water is filled and heated, the surface is oxidized and blackened. (It is not harmful if it is ingested.) ⇒ Use alumite treated product or non-aluminum product.</li> </ul>	—
	White matter adheres to a kettle, pan or pot.	<ul style="list-style-type: none"> <li>● Calcium which was dissolved in water is crystalized by heating. (It is not harmful if it is ingested.) ⇒ It becomes clear when soaked in vinegar diluted with hot water.</li> </ul>	—
	Hot water becomes cloudy.	<ul style="list-style-type: none"> <li>● Because of high pH value, calcium which was dissolved in water is crystalized by heating. (It is not harmful if it is ingested.) ⇒ Decrease pH value to use.</li> </ul>	22
	When rice is steamed with “alkaline ionized water” and kept warm, it becomes yellow.	<ul style="list-style-type: none"> <li>● Sugar and amino acids in rice react due to heat. (It is not harmful) ⇒ Decrease pH value to use.</li> </ul>	22
	When rice is steamed with “alkaline ionized water,” it is softened.	<ul style="list-style-type: none"> <li>● Rice starch is easily loosened by alkaline, and rice may be steamed softly. ⇒ Decrease pH value or use purified water.</li> </ul>	22
	Black matter adheres inside of the drainage hose.	<ul style="list-style-type: none"> <li>● Occurs due to adhesion of fungus in the air. ⇒ It is harmless, however, clean with a neutral detergent or replace with a new drainage hose.</li> </ul>	—
When sanitized water is used	Chlorine odor occurs from “sanitized water.”	<ul style="list-style-type: none"> <li>● It is the odor of “sanitized water” generated for cleaning. It is not a failure. ⇒ Chlorine odor may cause poor physical condition such as feeling ill, therefore, ventilate sufficiently.</li> </ul>	27 { 29
Other	When starting to pass water, the buzzer sounds.	<ul style="list-style-type: none"> <li>● This is an alarm sound when cleaning water is being discharged after automatically cleaning the inside of the main body. ⇒ When the total passing water amount of alkaline ionized water is less than 10 liters, automatic cleaning is not performed. (The buzzer also does not sound.)</li> </ul>	31
	Water comes out from the bottom of the product body.	<ul style="list-style-type: none"> <li>● There is a hole at the bottom of the main body to drain spilled water if water enters the product or the filter is replaced. ⇒ Wipe up the spilled water. The product can be used as it is.</li> </ul>	—
	“Click” sound is made from the main body.	<ul style="list-style-type: none"> <li>● This is an operating sound of parts after automatic cleaning in order to keep performance of this product. This does not indicate an abnormality.</li> </ul>	31

- If the product does not return to normal even after the above measures are taken, failure may occur, therefore, do not repair on your own and contact the store where you purchased this product.
- When not using for a long time, dry after cleaning and keep in a place with as little moisture as possible.



# Specifications

Product No.		HWP-55(EN)
Rated		AC220V 50-60Hz 1.5A
Water supply method		Discharge water tap corporation stop
Water supply connection		Lever selection
Structure		Water purifier (FW-13CM) main body built-in type
Power consumption		About 250W (Standby: About 0.4W)
Main body	Mass	About 5.7kg (When filled with water: About 6.6kg)
	Dimensions	255mm (width) ×120mm (depth) ×347mm (height)
Operable water temperature for passing water in main body		Lower than 35°C (Corporation stop, Lower than 60°C)
Operable water pressure (dynamic water pressure) for passing water in main body		70kPa~500kPa
Operable water pipe pressure (hydrostatic pressure)		70kPa~750kPa
Electrolysis generation water amount	Rated water amount	2.8L / min. (Water pressure 100kPa, when 20°C)
	Discharge port water amount	2.65L / min. (Water pressure 100kPa, when 20°C)
	Drainage port water amount	0.15L / min. (Water pressure 100kPa, when 20°C)
Continuously operable time		Alkaline ionized water: About 10 minutes (Note 1) Acidic water: About 5 minutes (Note 1) Strong alkaline ionized water: About 5 minutes (Note 1) Sanitized water: Max. 5 minutes (when 15g of salt is put in)
Filtering capacity	Filtering flow rate	2.5L/min.
	Free residual chlorine	16,000L (Note 2)
	Turbidity	16,000L (Note 3)
	Total trihalomethane	6,500L (Note 2)
	Soluble lead	7,500L (Note 2)
	CAT (Agricultural chemicals)	10,000L (Note 2)
	2-MIB (mold odor)	5,500L (Note 2)
	Tetrachloroethylene	16,000L (Note 2)
	Trichloroethylene	16,000L (Note 2)
	1, 1, 1- trichloroethane	5,500L (Note 2)
	Chloroform	5,500L (Note 2)
	Bromodichloromethane	15,000L (Note 2)
	Dibromochloromethane	16,000L (Note 2)
	Bromoform	16,000L (Note 2)
Rough standard for replacement When 16,000L is set as life	FW-02C/FW-11M: About 1 year (if 40L is used in a day) (Note 4) About 2 years (if 20L is used in a day)	
Length of power cord		2.5m
Power protection unit		Fuse (2A)

(Note 1) It may be shorter depending on the water quality, discharge amount, and usage environment.

(Note 2) Value of the removal rate 80% in JIS S 3201 test.

(Note 3) Value of the filter flow rate 50% in JIS S 3201 test.

(Note 4) This is a case where 40 liters are used per day. If the quantity consumed per day is larger, the replacement timing will be sooner. It may be even shorter depending on the quantity consumed, water quality, etc.

# MEMO

---

A series of horizontal dashed lines for writing.

# MEMO

---

A series of horizontal dashed lines for writing.

# **FUJIIRYŌKI**

---

**FUJI MEDICAL INSTRUMENTS MFG.CO.,LTD.**